

CANAL e ROSCA



YNOWA

MADE IN BRAZIL

FRESA PARA INTERPOLAR ROSCA INTERNA

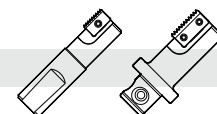

04

FRESA PARA INTERPOLAR ROSCA INTERNA DUPLO CORTE

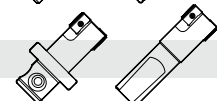

05

FRESA PARA INTERPOLAR ROSCA EXTERNA 4 CORTES

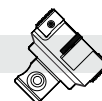

06

PASTILHA PARA INTERPOLAR ROSCA

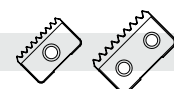

07

FRESA PARA INTERPOLAR ROSCA INTERNA

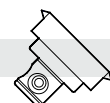

08

PASTILHA PARA INTERPOLAR ROSCA INTERNA



09

FRESA PARA INTERPOLAR CANAL - Haste Cilíndrica



10

FRESA PARA INTERPOLAR CANAL - Adaptação Modular

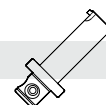

11

PORTA FERRAMENTAS PARA USINAGEM DE ROSCA E CANAL INTERNO

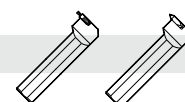

12

PORTA FERRAMENTAS PARA USINAGEM DE ROSCA E CANAL EXTERNO

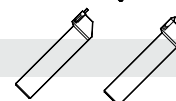

13

PASTILHA PARA ROSCA



14

PASTILHA PARA CANAL

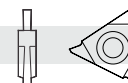

15

TABELA PARA SOLICITAÇÃO DE PASTILHA PARA CANAL



16

ANOTAÇÕES



17 - 18

DIMENSÕES EM mm(milímetros), QUANDO NÃO ESPECIFICADO.

RESERVAMO-NOS O DIREITO DE ALTERAR AS DIMENSÕES DOS PRODUTOS DESTA CATÁLOGO SEM PRÉVIO AVISO.

Fresa para interpolar rosca interna

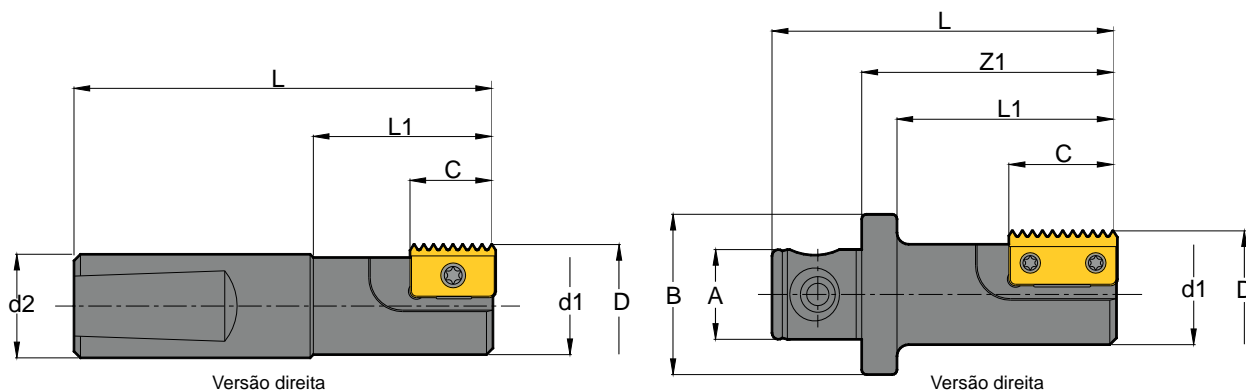

D	d1	d2	A x B	L	L1	Z1	C	Ø furo mín. (passagem)	CÓDIGO
12	10	20	-	105	25	-	13	16	5320 59 13-012 R/L
17	13	20	-	105	35	-	17	21	5320 59 17-017 R/L
25	20,5	25	-	106	40	-	17	29	5325 59 17-025 R/L
25	19	25	-	101	50	-	25	29	5325 59 25-025 R/L
36	29	32	-	128	70	-	25	40	5332 59 25-036 R/L
36	30	32	-	122	70	81	40	40	5332 59 32-036 R/L
45	36	40	-	160	90	101	40	49	5340 59 40-045 R/L
36	30	-	28 x 50	122	70	81	40	40	130 59 40-036 R/L
45	36	-	28 x 50	160	90	101	40	49	130 59 40-045 R/L

Exemplo para pedido: 10 pçs - **5320 59 13-012 R**
Solicitar pastilhas separadamente.

R - ferramenta corte direito
L - ferramenta corte esquerdo

Pastilhas - pág. 7

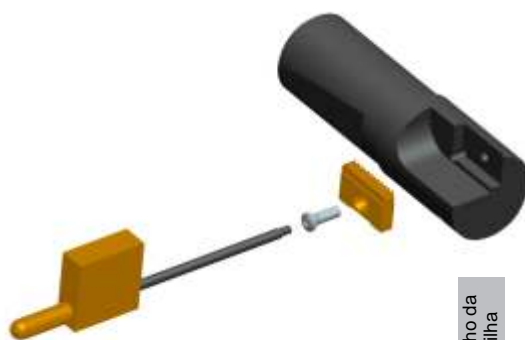

Parafuso	Chave	C
WPT 02 002	UCT 07 001	13
WPT 03 005	UCT 09 001	17
WPT 04 002	UCT 15 001	25
WPT 04 002	UCT 15 001	40

Exemplo para pedido: 10 pçs - **WPT 02 002**

Observações:

1) Z1 / L1 menor ou maior que o indicado, somente sob consulta

2) Sistema com refrigeração interna 

Fresa para interpolar rosca externa 4 cortes

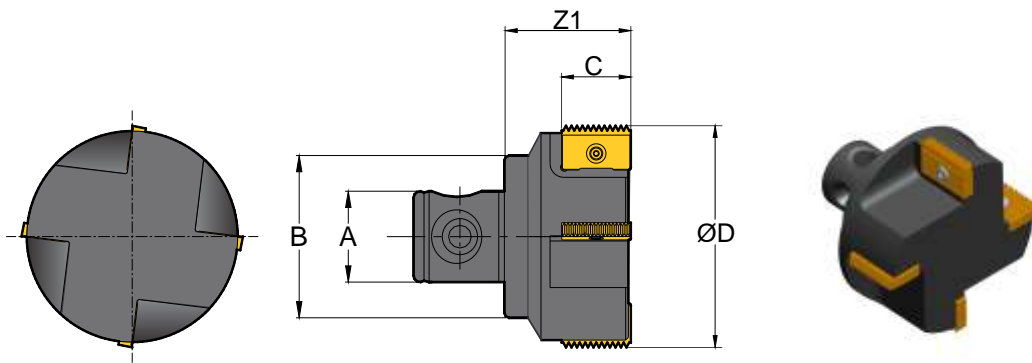

A	B	tamanho da pastilha C	Z1	D	Codigo
28	50	17	50	63	130 59 17-063
36	63	25	55	80	140 59 25-080
36	80	25	60	100	150 59 25-100

Exemplo para pedido: 10 pçs - **140 59 17-063**

Solicitar pastilhas separadamente.

Pastilhas - pág. 7

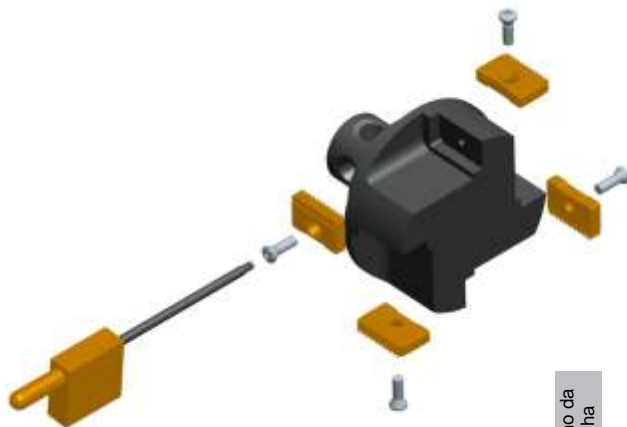

Parafuso	Chave	tamanho da pastilha C
WPT 02 002	UCT 07 001	13
WPT 03 005	UCT 09 001	17
WPT 04 002	UCT 15 001	25
WPT 04 002	UCT 15 001	40

Exemplo para pedido: 10 pçs - **WPT 02 002**

Observações:

1) Z1 menor ou maior que o indicado, somente sob consulta

2) Sistema com refrigeração interna 

Fresa para interpolar rosca interna duplo corte

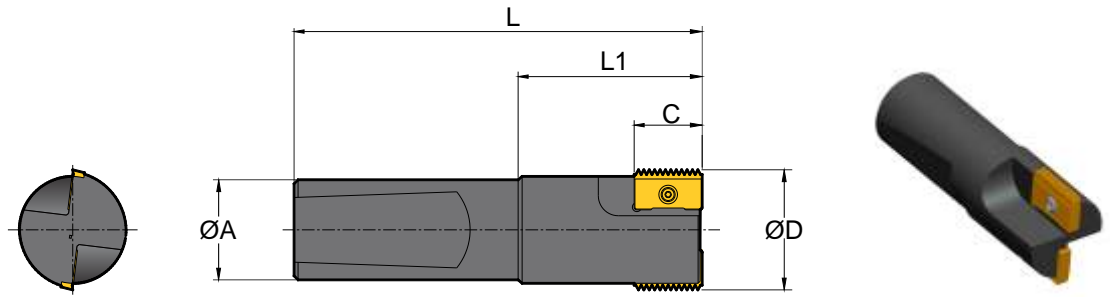

A	tamanho da pastilha C	L	L1	D	CÓDIGO
20	13	95	45	20	5320 59 13-020
25	17	102	45	30	5325 59 17-030
32	25	105	45	40	5332 59 25-040
40	40	109	70	50	5340 59 40-050

Exemplo para pedido: 10 pçs - **5320 59 13-020**

Solicitar pastilhas separadamente.

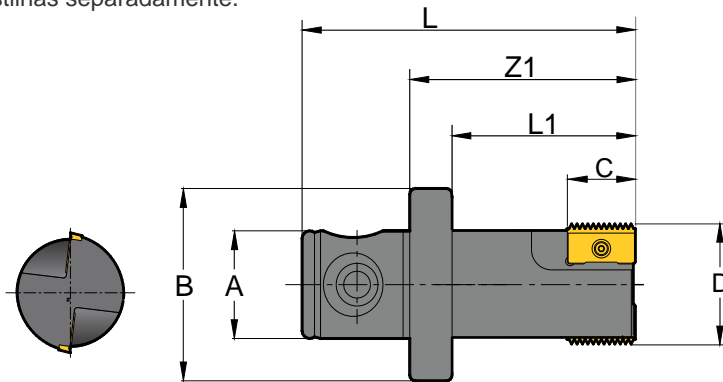

A	B	tamanho da pastilha C	L	L1	Z1	D	CÓDIGO
18	32	13	77	45	55	20	110 59 13-020
22	40	17	84	45	56	30	120 59 17-030
28	50	25	84	45	56	40	130 59 25-040
28	50	40	109	70	81	50	130 59 40-050

Exemplo para pedido: 10 pçs - **110 59 13-020**

Solicitar pastilhas separadamente.

Pastilhas - pág. 7



Parafuso	Chave	tamanho da pastilha C
WPT 02 002	UCT 07 001	13
WPT 03 005	UCT 09 001	17
WPT 04 002	UCT 15 001	25
WPT 04 002	UCT 15 001	40





Exemplo para pedido: 10 pçs - **WPT 02 002**

Observações:

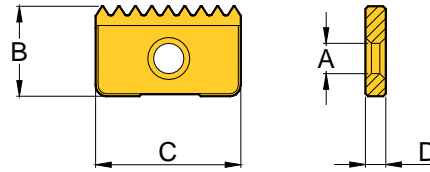
1) Z1 / L1 menor ou maior que o indicado, somente sob consulta

2) Sistema com refrigeração interna 



	tamanho da pastilha					
	A	B	C	D	Rosca	CÓDIGO
1 fio de corte  Furo de passagem mín. Ø16 - haste Ø20	2,9	7	13	2,5	1.0 MF	LNMX 13 02 07
					1.5 MF	
					2.0 MF	
					18 NPT	
1 fio de corte  Furo de passagem mín. Ø21 - haste Ø20 mín. Ø29 - haste Ø25	3,5	10	17	3	1.0 MF	LNMX 17 03 10
					1.5 MF	
					2.0 MF	
					2.5 M	
					3.0 M / MF	
					8 UNC	
					12 UNF	
					14 UNF	
					18 UNEF	
					11.5 NPT	
14 NPT						
11.5 NPTF						
2 fios de corte  Furo de passagem mín. Ø29 - haste Ø25 mín. Ø40 - haste Ø32	4,7	16	25	5	1.0 MF	LNMX 25 05 16
					1.5 MF	
					2.0 MF	
					3.0 MF	
					4 M / MF	
					4 UNC	
					5 UNC	
					6 UNC	
					7 UNC	
					12 UNF	
18 UNEF						
11.5 NPT						
2 fios de corte  Furo de passagem mín. Ø40 - haste Ø32 mín. Ø49 - haste Ø40	5,6	20	40	6	2.0 MF	LNMX 40 06 20
					3.0 MF	
					4.0 MF	
					4.5 M	
					5.0 M	
					5.5 M	
					6.0 M	
					4 UNC	
					5 UNC	
					18 UNEF	
8 NPT						
11.5 NPT						

Exemplo para pedido: 10 pçs - LNMX 17 03 10 - 1.5MF - K K - ferro fundido
 Código Rosca Classe P - aço AL - alumínio

Para outros tipos de roscas (dente de serra, rosca redonda, etc.), diferente do indicado, somente sob consulta.

M - rosca métrica grossa
 MF - rosca métrica fina
 UNC - rosca unificada série grossa
 UNEF - rosca unificada série extra fina

Obs:
Especificar junto ao código, o tipo da rosca e a classe do material à ser usinado.

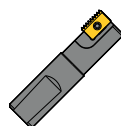

Fresas - pág. 4,5,6

Fresa para interpolar rosca interna

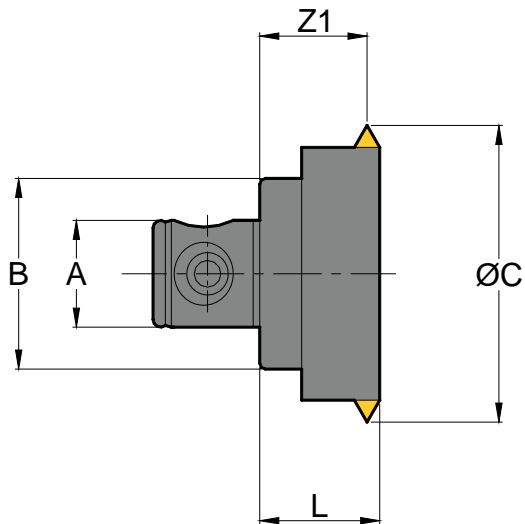

FRESA

A x B	Rosca interna		ØC	L	Z1	Número de pastilhas	CÓDIGO Fresa	Passo	CÓDIGO Pastilha
	Ømin	Ømáx							
18 x 32	52	64	41	47	45	4	110 59 09-041	1,5-5,5	LNMX 09 03 06
22 x 40	64	76	51	62	60	4	120 59 15-051	1,5-6,5	LNMX 15 04 09
28 x 50	76	96	60	72	70	4	130 59 15-060		
36 x 63	96	116	80	73	70	6	140 59 19-080	1,5-6,5	LNMX 19 06 12
36 x 80	116	142	96	73	70	6	150 59 19-096		
36 x 80	142	-	112	73	70	8	150 59 19-112		

Exemplo para pedido: 10 pçs - **110 59 09-041**

Solicitar pastilhas separadamente.

Pastilhas - pág. 9

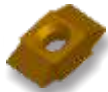

Observações:

1) Z1 menor ou maior que o indicado, somente sob consulta

2) Sistema com refrigeração interna



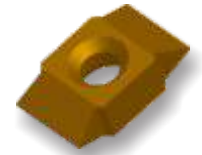
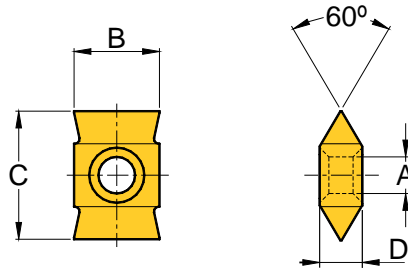

Pastilha com
4 fios de corte

A	B	C	D	Passo	CÓDIGO
2,80	6,35	9,525	3,18	1,5 a 5,5	LNMX 09 03 06
4,27	9,525	15,875	4,76	1,5 a 6,5	LNMX 15 04 09
5,45	12,7	19,05	6,35	1,5 a 6,5	LNMX 19 06 12

Exemplo para pedido: 30 pçs - **LNMX 09 03 06**

Fresa - pág. 8



**Para especificação da classe da pastilha e cobertura,
indicar o material a ser usinado na solicitação.**

Fresa para interpolar canal

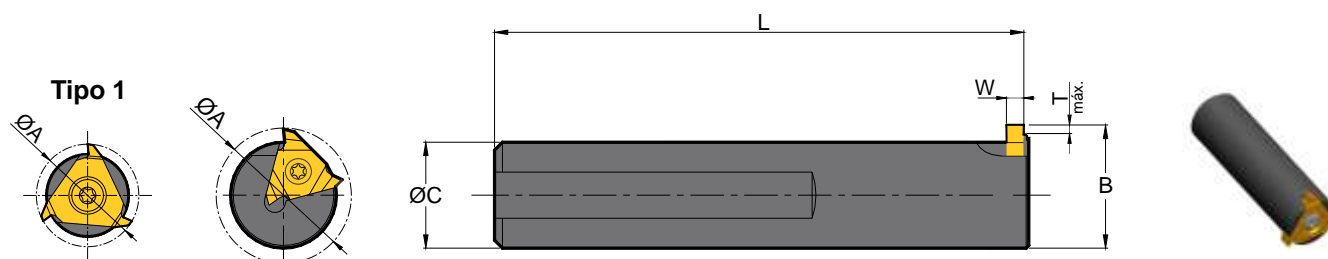

A	B	C	L	W ± 0.02	T máx.	C.I.	CÓDIGO
21 tipo 1	18	20	100	1,3 à 3,18	2	9,53	5318 59 16-021
25	22	20	100	1,3 à 3,18	2	9,53	5322 59 16-025
30	28	25	150	3,18 à 4,76	3	12,7	5328 59 22-030

Exemplo para pedido: 10 pçs - **5318 59 16-021**



Pastilhas:
pág. 15

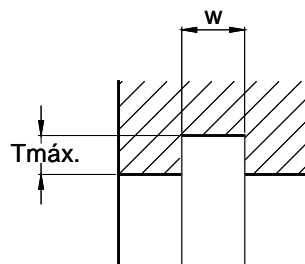

Componentes

Parafuso	Chave	C.I.(pastilha)
WPT 02 002	UCT 07 001	9,53
WPT 03 005	UCT 09 001	9,53
WPT 04 002	UCT 15 001	12,7

Exemplo para pedido: 10 pçs - **WPT 02 002**

Observações:

1) Z1 menor ou maior que o indicado,
somente sob consulta

2) Sistema com refrigeração interna



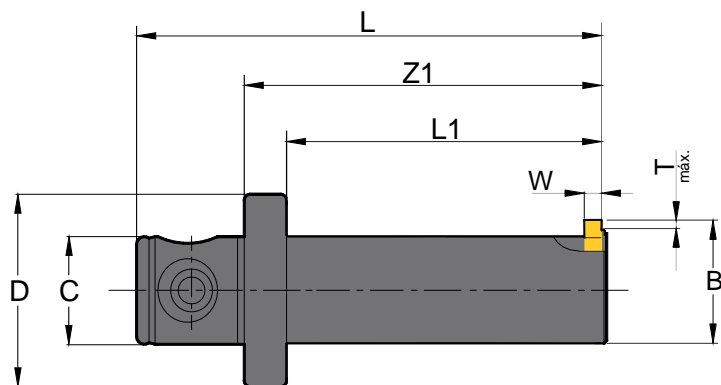
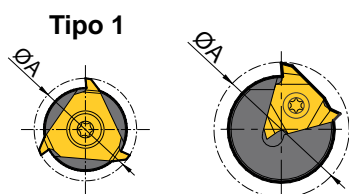

A	B	C	D	L	L1	Z1	W ± 0.02	T máx.	C.I.(pastilha)	CÓDIGO
21 tipo 1	18	18	32	100	68	78	1,3 à 3,18	2	9,53	110 59 16-021
25	22	22	40	100	61	72	1,3 à 3,18	2	9,53	120 59 16-025
30	28	28	50	150	111	122	3,18 à 4,76	3	12,7	130 59 22-030

Exemplo para pedido: 10 pçs - **110 59 16-021**



Pastilhas:
pág. 15

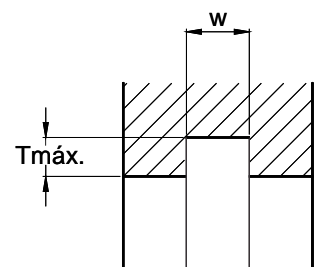

Componentes

Parafuso	Chave	C.I.(pastilha)
WPT 02 002	UCT 07 001	9,53
WPT 03 005	UCT 09 001	9,53
WPT 04 002	UCT 15 001	12,7

Exemplo para pedido: 10 pçs - **WPT 02 002**

Observações:

1) Z1 menor ou maior que o indicado, somente sob consulta

2) Sistema com refrigeração interna 

Porta ferramentas para usinagem de rosca e canal interno

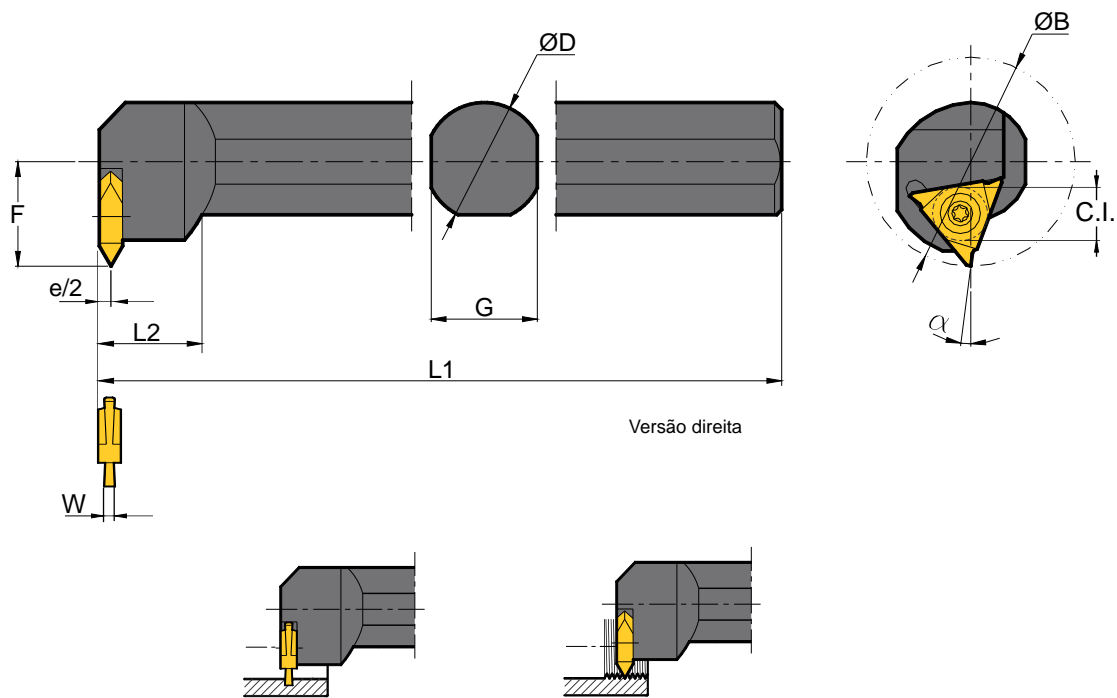

C.I.	B	D	G	L1	L2	F	CÓDIGO
9,525	35	25	23	200	18	18	S25R-PTXNR/L 09
	45	32	30	250	20	23	S32S-PTXNR/L 09
12,7	45	32	30	250	20	23	S32S-PTXNR/L 12
	50	40	30	250	20	23	S40S-PTXNR/L 12

Exemplo para pedido: 10 pçs - **S25R-PTXNR 09**
Solicitar pastilhas separadamente.

R - ferramenta corte direito
L - ferramenta corte esquerdo



Pastilhas:
pág. 14, 15

Observações:

1) L1 e/ou F menor ou maior que o indicado,
somente sob consulta

Porta ferramentas para usinagem de rosca e canal externo

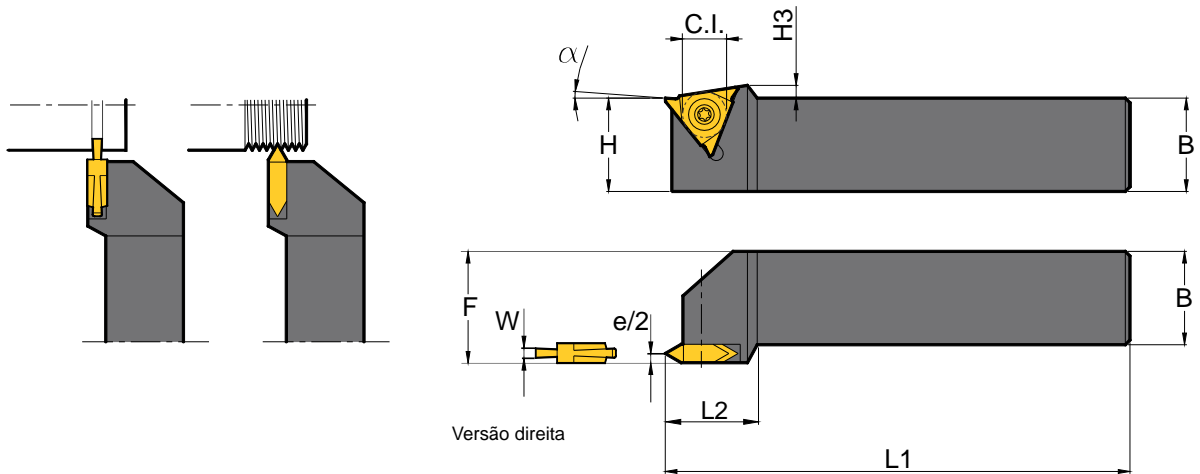

C.I.	H	B	H3	L1	L2	F	CÓDIGO
9,525	16	16	2,5	100	18	20	STGNL 1616-H16 R/L
	20	20	2,5	125	18	25	STGNL 2020-K16 R/L
	25	25	2,5	150	18	30	STGNL 2525-M16 R/L
12,7	20	20	3,0	125	25	25	STGNL 2020-K22 R/L
	25	25	3,0	150	25	30	STGNL 2525-M22 R/L
	25	32	3,0	150	27	35	STGNL 2532-M22 R/L
	32	32	3,0	150	27	35	STGNL 3232-M22 R/L

Exemplo para pedido: 10 pçs - **STGNL 1616-H16 R**
Solicitar pastilhas separadamente.

R - ferramenta corte direito
L - ferramenta corte esquerdo



Pastilhas:
pág. 14, 15

Observações:
1) L1 e/ou F menor ou maior que o indicado,
somente sob consulta

Pastilha para usinagem de rosca

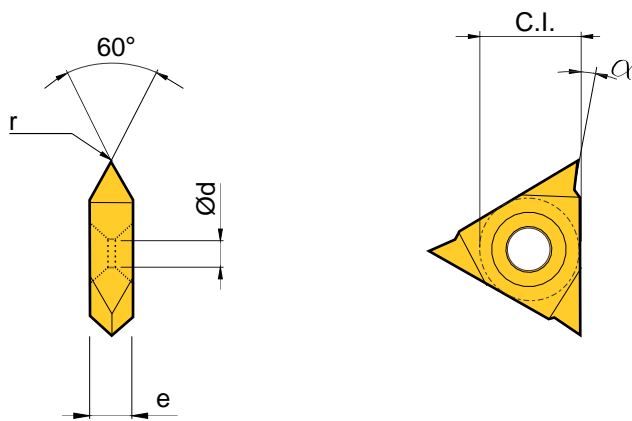

C.I.	e	Ød	Passo	r (raio)	CÓDIGO
9,525	3,18	3,81	0,5	0,2	TNMC - 32 NV
			0,75		
			1,0		
			1,25		
			1,5		
			1,75		
			2,0		
			2,5		
12,7	4,76	5,13	2,5	0,3	TNMC - 43 NV
			3,0		
			3,5		
			4,0		
			4,5		
			5,0		
			5,5		
			6,0		

Exemplo para pedido: 10 pçs - **TNMC - 32 NV**

Obs:
Para especificação da classe da pastilha e cobertura, indicar o material a ser usinado na solicitação.

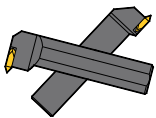

porta ferramentas
pág. 12, 13

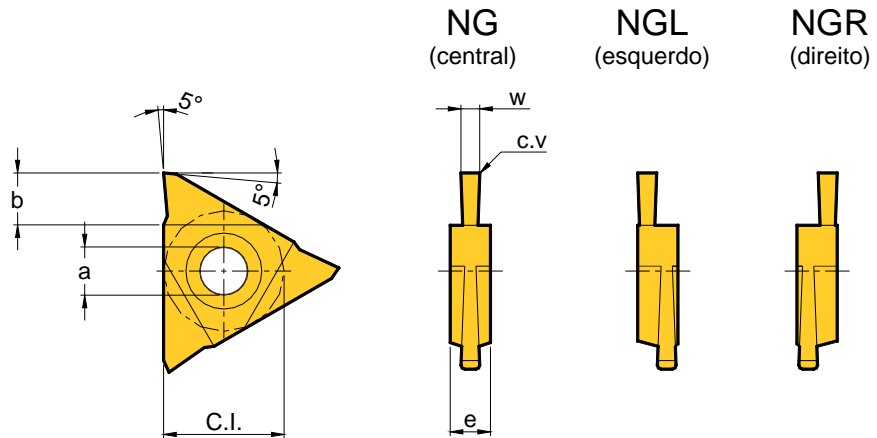

C.I.	a	b (máx.)	e	W		CÓDIGO
				Min.	Max.	
9,53	3,8	4	3,18	1,3	3,18	TNMC 32
12,7	5,1	5,8	4,76	3,18	4,76	TNMC 43

Exemplo para pedido: 10 pçs - **TNMC 32 NGR - W = 2,0**

Obs:
Para especificação da classe da pastilha e cobertura,
indicar o material a ser usinado na solicitação.

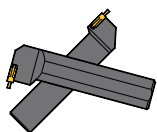

porta ferramentas
pág. 10, 11, 12, 13

Tabela para solicitação de pastilha para canal

Preencher com as devidas informações e nos enviar por e-mail ou fax.

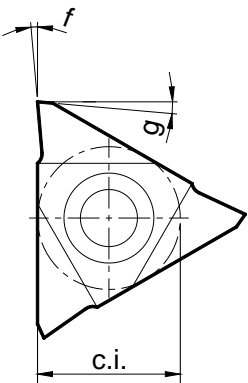
 <p> $c.i. =$ <input type="text" value="9.525 ou 12.7"/> </p> <p> $f =$ <input type="text" value="Padrão 5°"/> </p> <p> $g =$ <input type="text" value="Padrão 5°"/> </p>	<table border="1" style="margin-left: auto; margin-right: auto;"> <thead> <tr> <th rowspan="2">C.I.</th> <th colspan="2">W</th> </tr> <tr> <th>mín.</th> <th>máx.</th> </tr> </thead> <tbody> <tr> <td>9.525</td> <td>1,58</td> <td>3,18</td> </tr> <tr> <td>12.7</td> <td>3,18</td> <td>4,76</td> </tr> </tbody> </table> <p> $W =$ <input type="text"/> </p> <p>observar espessura do canal máx. e mín.</p> <p> $b =$ <input type="text"/> </p> <p> $e =$ <input type="text" value="3.18 / 4.76"/> </p>	C.I.	W		mín.	máx.	9.525	1,58	3,18	12.7	3,18	4,76
C.I.	W											
	mín.	máx.										
9.525	1,58	3,18										
12.7	3,18	4,76										

dimensões em mm(milímetros)

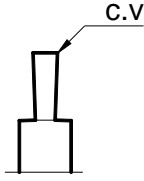
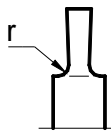
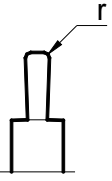
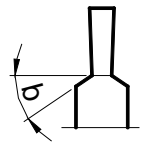
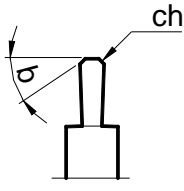
 <p> $c.v. =$ <input type="text" value="sim"/> <input type="text" value="não"/> </p>	 <p> $r =$ <input type="text"/> </p>
 <p> $r =$ <input type="text"/> </p>	 <p> $b =$ <input type="text"/> </p>
 <p> $ch =$ <input type="text" value="Padrão 45°"/> </p> <p> $b =$ <input type="text"/> </p>	<p> <i>✎</i> Para especificação da classe da pastilha e cobertura, indicar o material a ser usinado na solicitação. material usinado = <input type="text"/> </p> <p> <i>✎</i> Dados indicados da pastilha, serão avaliados tecnicamente. </p>

Croqui:

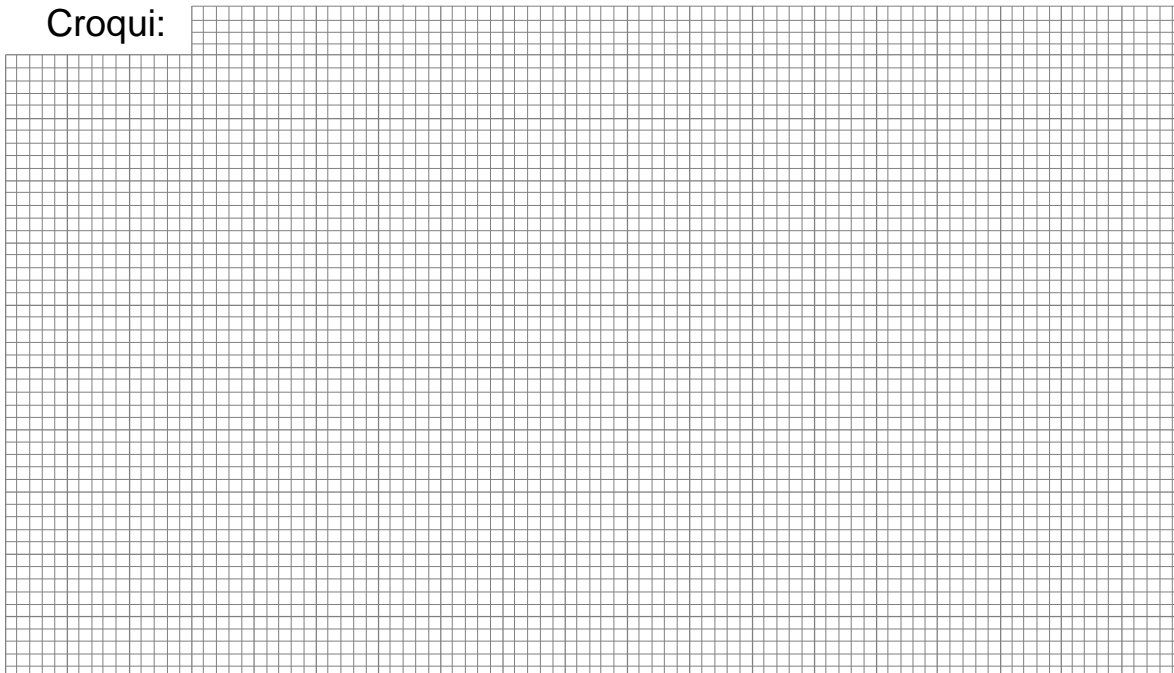











Handwritten notes in the first section of the page, consisting of approximately 10 lines of text.



Handwritten notes in the second section of the page, consisting of approximately 10 lines of text.



Handwritten notes in the third section of the page, consisting of approximately 10 lines of text.



Handwritten notes in the final section of the page, consisting of approximately 5 lines of text.

ISO 9001
BUREAU VERITAS
Certification



YNOWA FERRAMENTAS LTDA
RUA CLÁUDIA SOARES, N° 153 - BAIRRO PORTAL DO SOL
SÃO JOSÉ DOS PINHAIS - PARANÁ - CEP 83020-790
Fone: (41)3595-4545 - Fax: (41)3595-4546
CNPJ: 08.089.188/0001-06
INSC. EST.: 90.375.281-50
E-mail: ynowa@ynowa.com.br
Site: www.ynowa.com.br

Representante: _____