

SUPORTES VDI

VDI Toolholders

Rev. 1

SISTEMA VDI 3425 - DIN 69 880

VDI 3425 - DIN 69 880 SYSTEM



YNOWA

MADE IN BRAZIL

Reservamos o direito de alterar as dimensões dos produtos deste catálogo sem prévio aviso.
All tool specifications are subject to change without prior notice.

Dimensões em mm(milímetros), quando não especificado.
All dimensions, when not specified, consider as mm(millimeter)

	VDI Produtos VDI Products	Forma form	Página page
	Haste DIN 69 880 - <i>Din 69 880 shank</i>		05
	Haste Modular - <i>Modular Shank Adaptation</i>		06
	Transversal / Direita / Curta - <i>right-hand short</i>	B1	07
	Transversal / Esquerda / Curta - <i>left-hand short</i>	B2	08
	Transversal / Inversa / Direita / Curta - <i>right-hand short inverted</i>	B3	09
	Transversal / Inversa / Esquerda / Curta - <i>left-hand short inverted</i>	B4	10
	Transversal / Direita / Longa - <i>right-hand long</i>	B5	11
	Transversal / Esquerda / Longa - <i>left-hand long</i>	B6	12
	Transversal / Inversa / Direita / Longa - <i>right-hand long inverted</i>	B7	13
	Transversal / Inversa / Esquerda / Longa - <i>left-hand long inverted</i>	B8	14
	Longitudinal / Direita - <i>square right-hand</i>	C1	15
	Longitudinal / Esquerda - <i>square left-hand</i>	C2	16
	Longitudinal / Inversa / Direita - <i>square right-hand inverted</i>	C3	17
	Longitudinal / Inversa / Esquerda - <i>square left-hand inverted</i>	C4	18
	Múltiplo / Transversal / Longitudinal - <i>square</i>	D1	19
	Múltiplo / Transversal / Longitudinal / Inversasquare- <i>inverted</i>	D2	20
	Adaptador para Haste Cilíndrica - <i>shaft drill adaptation</i>	E1	21
	Adaptador para Haste Cilíndrica com facetado - <i>cylindrical shaft</i>	E2	22
	Bucha Redutora Tipo "C" - <i>Toolholder Bushing Type "C"</i>		23
	Buchas Redutoras - <i>reducing sleeve</i>		24
	Adaptador para Haste Cilíndrica com ou sem facetado - <i>cylindrical shaft with or without mill</i>		24
	Adaptador Porta pinça - <i>collet chuck</i>	E4	25
	Adaptador Cone Morse Interno - <i>morse taper socket</i>	F	26
	Adaptador Porta-Macho Tipo "S" - <i>tap holder adaptation - type "S"</i>		27
	Adaptador Porta-Macho Troca Rápida - <i>tap holder adaptation - quick change</i>		28
	Adaptador Cone Din 238 - <i>taper adaptation - Din 238</i>		29
	Adaptador Cone ISO/R 239(Jacob's) - <i>taper adaptation - ISO/R 239(Jacob's)</i>		30
	Anel de Encosto - <i>clamping ring</i>	Z1	31
	Tampão - <i>plug</i>	Z2	31

VDI - Orientação VDI Orientation Chart

- Z1 menor ou maior que o indicado, somente sob consulta
Z1 dimension different than presented, only with previous consult
- Sistema com refrigeração
With coolant system

Sentido Horário de Rotação do Eixo Árvore *Left-Hand(Clockwise)Spindle Rotation*

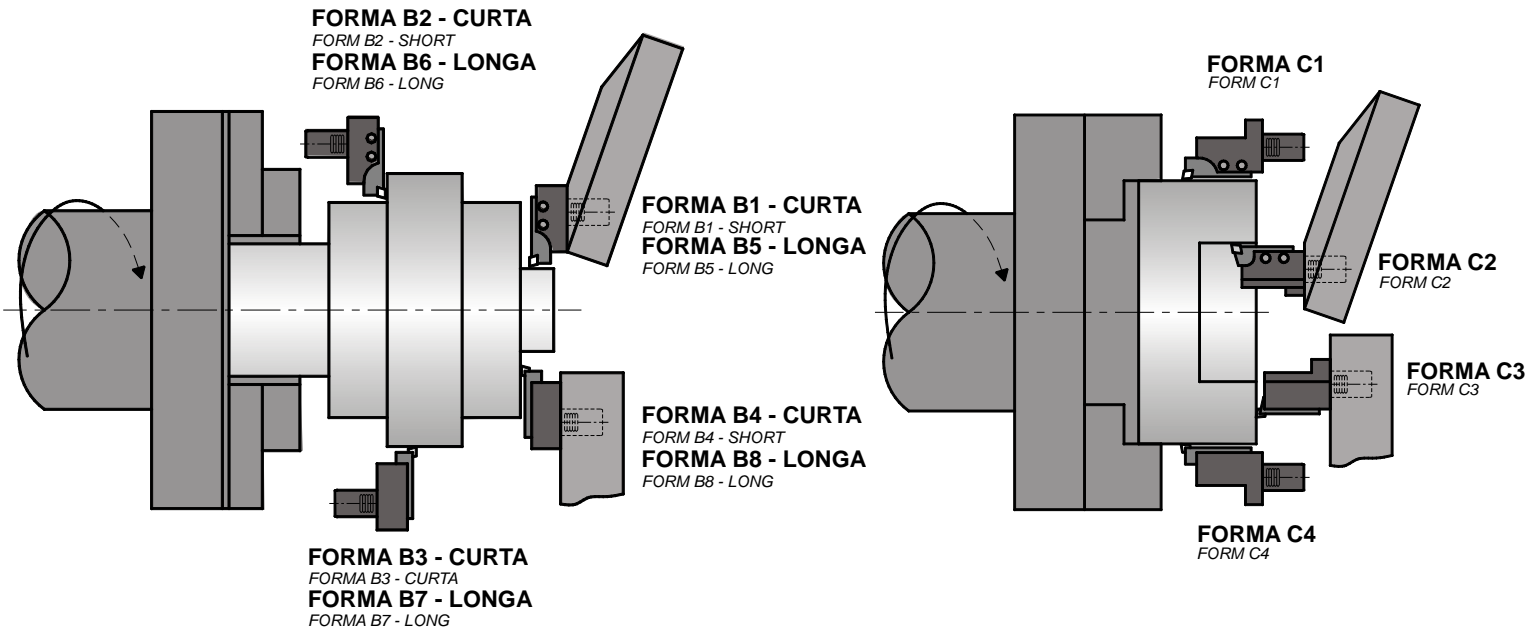

Sentido Anti-Horário de Rotação do Eixo Árvore *Right-Hand(Counter-Clockwise)Spindle Rotation*

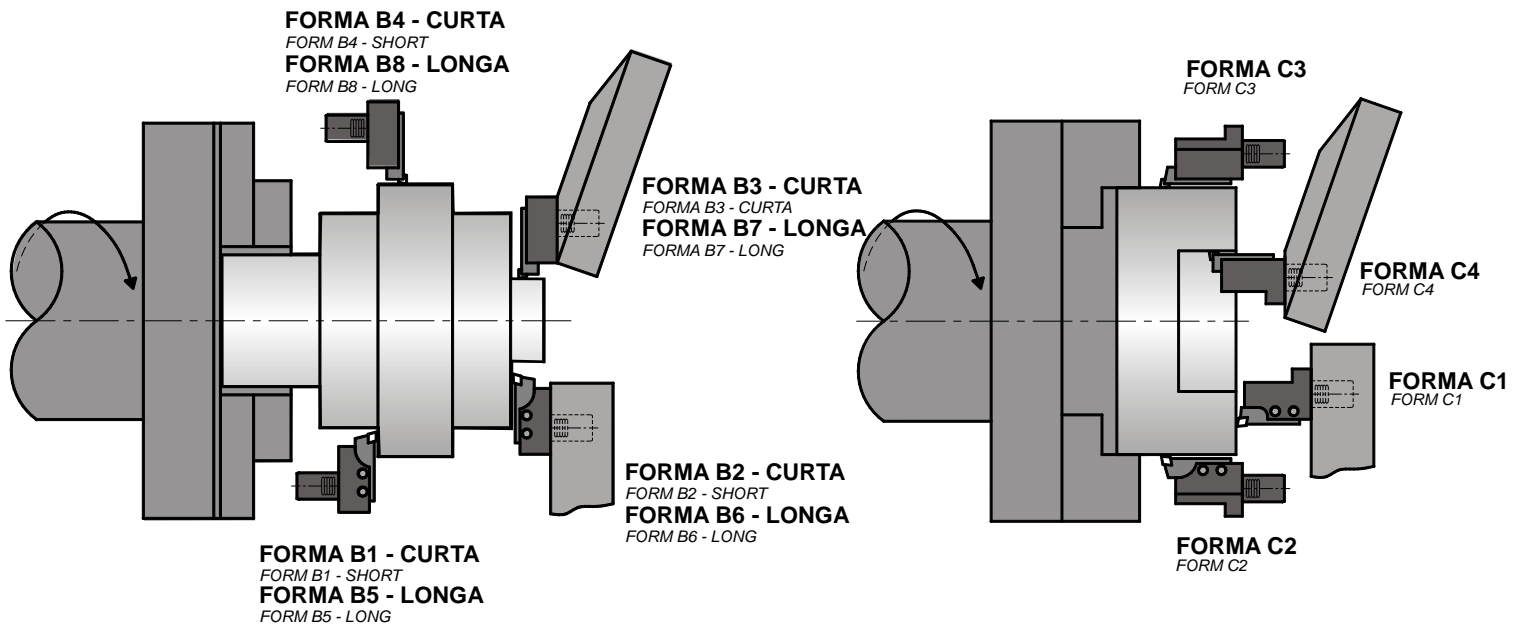

DIMENSÕES DA HASTE DIN 69 880 *DIN 69 880 SHAFT DIMENSION*

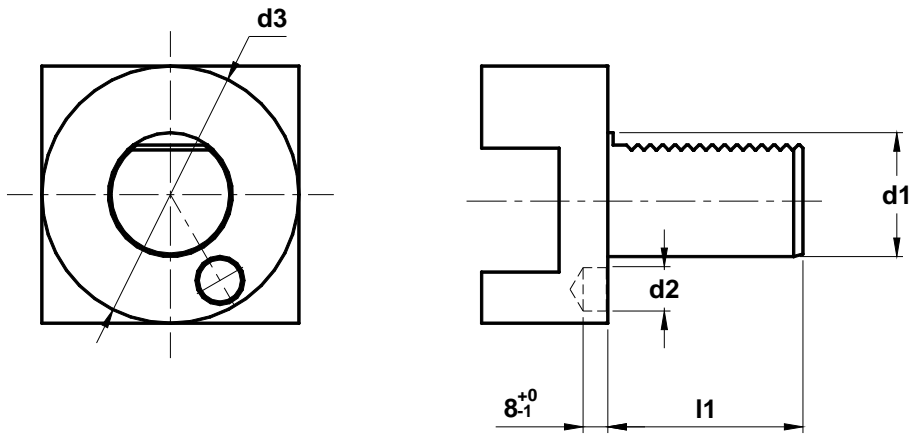

DIMENSÕES DA ADAPTAÇÃO ADAPTATION DIMENSIONS				
d1	l1	d2	d3	
16	32	8	40	
20	40	10	50	
25	48	10	58	
30	55	14	68	
40	63	14	83	
50	78	16	98	
60	94	16	123	
80	124	20	158	

**HASTE DIN 69 880
COM ADAPTAÇÃO
HASTE MODULAR**

*DIN 69 880 WITH MODULAR
SHANK ADAPTATION*

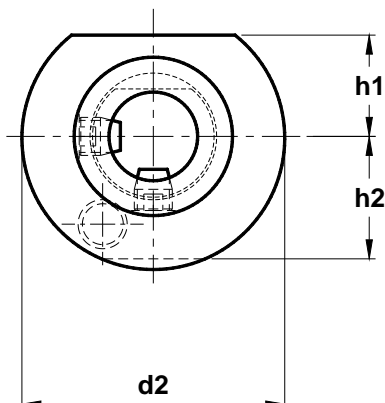
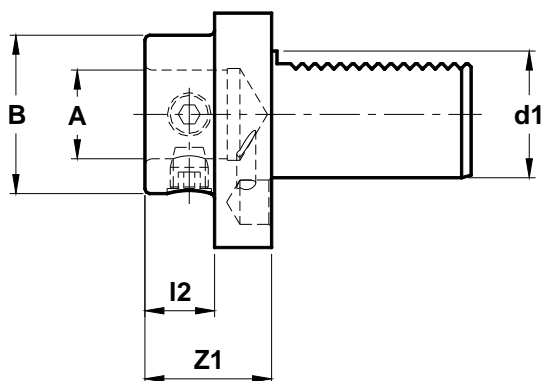

DIMENSÕES DA ADAPTAÇÃO ADAPTATION DIMENSIONS								Ref.	CÓDIGO Code
d1	A	B	d2	h1	h2	l2	Z1		
30	28	50	68	28	30	22	40	613 90 30	2005400003
	36	63	68	28	30	32	50	613 90 40	2005400004
40	28	50	83	32.5	-	22	40	614 90 30	2005400005
	36	63	83	32.5	-	32	50	614 90 40	2005400006

Exemplo para pedido / Ordering example : 10 pçs - **2005400003**

APLICAÇÃO HASTE MODULAR MODULAR SHANK ADAPTATION

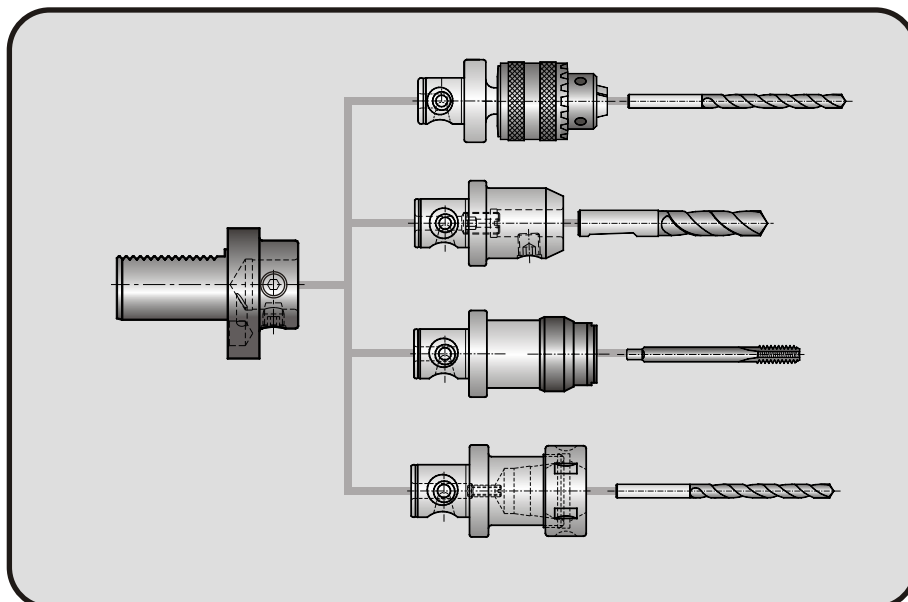

**HASTE DIN 69 880, COM ADAPTAÇÃO
PARA HASTE QUADRADA
TRANSVERSAL / DIREITA / CURTA
DIN 69 880 - B1**

*DIN 69 880 / RIGHT-HAND SHORT
FORM - B1*

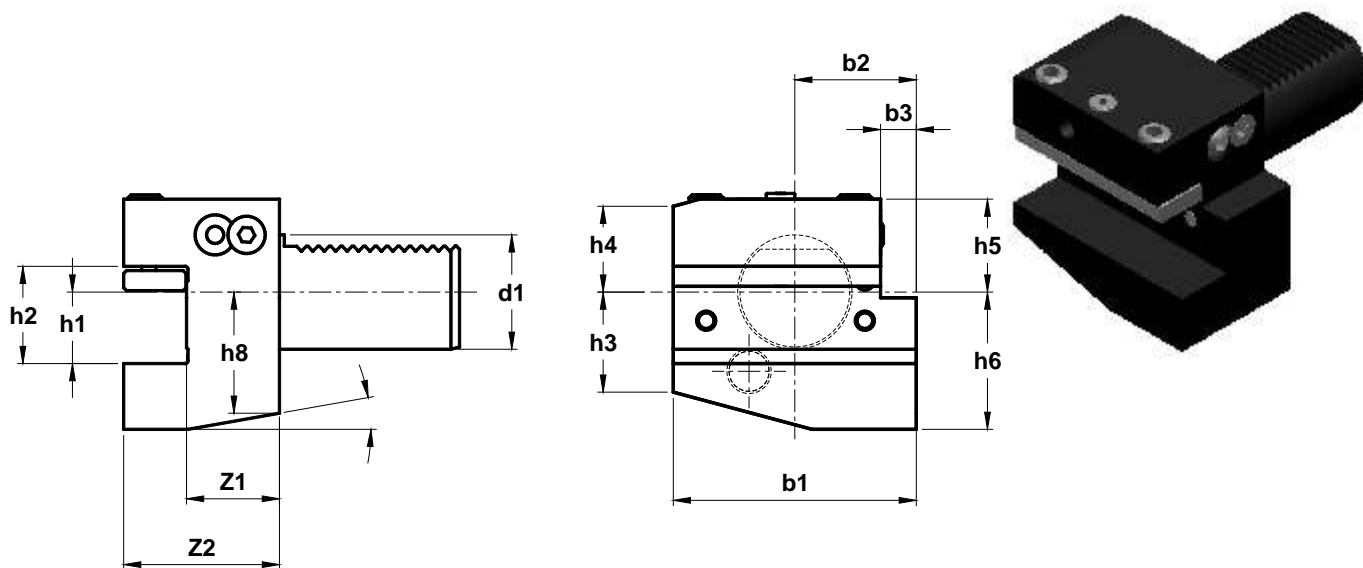

DIMENSÕES DA ADAPTAÇÃO ADAPTATION DIMENSIONS														Ref.	CÓDIGO Code
d1	b1	b2	b3	h1	h2	h3	h4	h5	h6	h8	Z1	Z2	α		
20	55	30	7	16	22	19	19	25	30	23	16	30	30°	632 01 16	20054000007
30	70	35	10	20	29	26	22	28	38	30	22	40	25°	633 01 20	20054000009
40	85	42.5	12.5	25	34	35	30	32.5	48	-	22	44	-	634 01 25	20054000011
50	100	50	16	32	41	42	35	35	60	-	30	55	-	635 01 32	20054000012
60	125	62.5	16	32	41	46	42.5	42.5	62.5	-	30	60	-	636 01 32	20054000013
80	160	80	20	40	53	60	55	55	80	-	40	75	-	638 01 40	20054000014

Exemplo para pedido / Ordering example : 10 pçs - **20054000007**

**HASTE DIN 69 880, COM ADAPTAÇÃO
PARA HASTE QUADRADA
TRANSVERSAL / ESQUERDA / CURTA
DIN 69 880 - B2**

*DIN 69 880 / LEFT-HAND SHORT
FORM - B2*

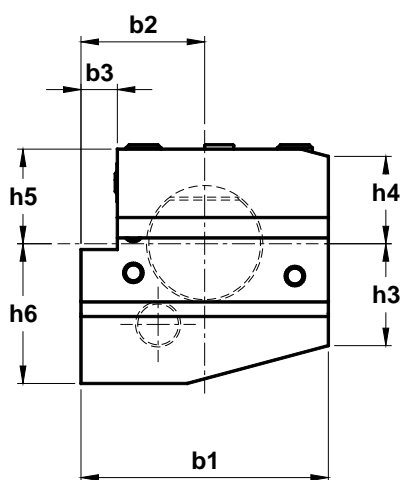
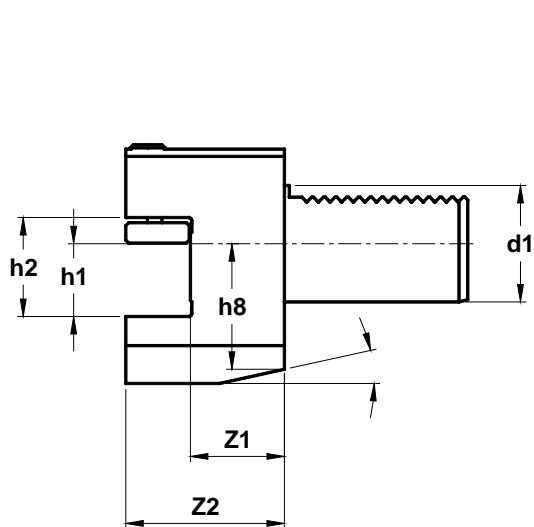

DIMENSÕES DA ADAPTAÇÃO
ADAPTATION DIMENSIONS

d1	b1	b2	b3	h1	h2	h3	h4	h5	h6	h8	Z1	Z2	α	Ref.	CÓDIGO Code
20	55	30	7	16	22	19	19	25	30	23	16	30	30°	632 02 16	20054000015
30	70	35	10	20	29	26	22	28	38	30	22	40	25°	633 02 20	20054000017
40	85	42.5	12.5	25	34	35	30	32.5	48	-	22	44	-	634 02 25	20054000019
50	100	50	16	32	41	42	35	35	60	-	30	55	-	635 02 32	20054000020
60	125	62.5	16	32	41	46	42.5	42.5	62.5	-	30	60	-	636 02 32	20054000021
80	160	80	20	40	53	60	55	55	80	-	40	75	-	638 02 40	20054000022

Exemplo para pedido / Ordering example : 10 pçs - **20054000015**

**HASTE DIN 69 880, COM ADAPTAÇÃO
PARA HASTE QUADRADA
TRANSVERSAL / POSIÇÃO INVERSA / DIREITA / CURTA
DIN 69 880 - B3**

*DIN 69 880 / RIGHT-HAND SHORT INVERTED
FORM - B3*

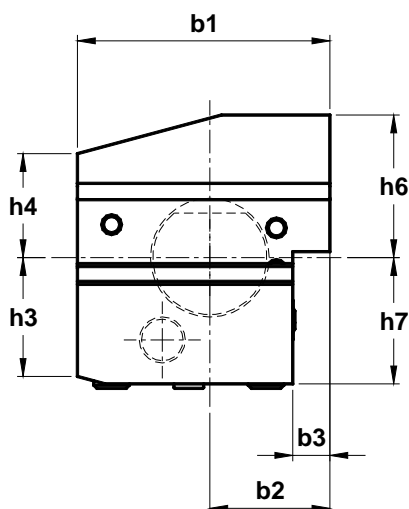
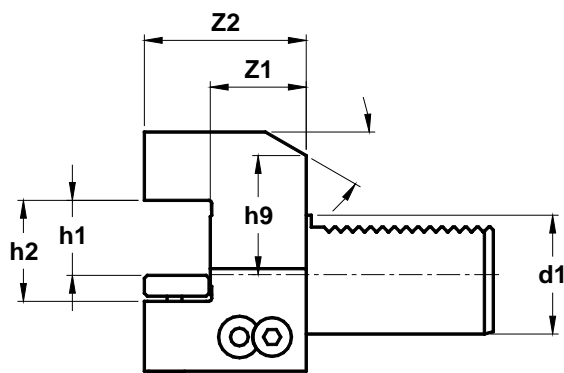

DIMENSÕES DA ADAPTAÇÃO
ADAPTATION DIMENSIONS

d1	b1	b2	b3	h1	h2	h3	h4	h6	h7	h9	Z1	Z2	α	Ref.	CÓDIGO <i>Code</i>
20	55	30	7	16	22	19	19	30	25	23	16	30	30°	632 03 16	20054000023
30	70	35	10	20	29	26	22	38	35	28	22	40	25°	633 03 20	20054000025
40	85	42.5	12.5	25	34	35	30	48	42.5	-	22	44	-	634 03 25	20054000027
50	100	50	16	32	41	42	35	60	50	-	30	55	-	635 03 32	20054000028
60	125	62.5	16	32	41	46	42.5	62.5	62.5	-	30	60	-	636 03 32	20054000029
80	160	80	20	40	53	60	55	80	80	-	40	75	-	638 03 40	20054000030

Exemplo para pedido / *Ordering example* : 10 pçs - **20054000024**

VDI SUPORTES / VDI Turning Toolholders

**HASTE DIN 69 880, COM ADAPTAÇÃO
PARA HASTE QUADRADA
TRANSVERSAL / POSIÇÃO INVERSA / ESQUERDA / CURTA
DIN 69 880 - B4**

*DIN 69 880 / LEFT-HAND SHORT INVERTED
FORM - B4*

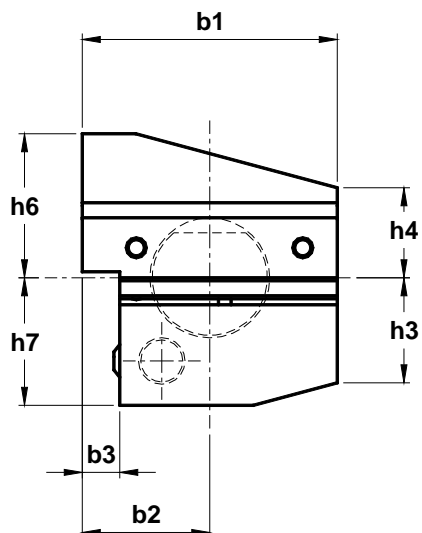
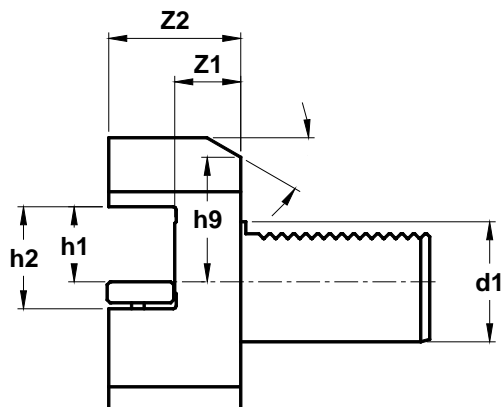

DIMENSÕES DA ADAPTAÇÃO
ADAPTATION DIMENSIONS

d1	b1	b2	b3	h1	h2	h3	h4	h6	h7	h9	Z1	Z2	α	Ref.	CÓDIGO Code
20	55	30	7	16	22	19	19	30	25	23	16	30	30°	632 04 16	20054000031
30	70	35	10	20	29	26	22	38	35	28	22	40	25°	633 04 20	20054000033
40	85	42.5	12.5	25	34	35	30	48	42.5	-	22	44	-	634 04 25	20054000035
50	100	50	16	32	41	42	35	60	50	-	30	55	-	635 04 32	20054000036
60	125	62.5	16	32	41	46	42.5	62.5	62.5	-	30	60	-	636 04 32	20054000037
80	160	80	20	40	53	60	55	80	80	-	40	75	-	638 04 40	20054000038

Exemplo para pedido / Ordering example : 10 pçs - **20054000031**

HASTE DIN 69 880, COM ADAPTAÇÃO
PARA HASTE QUADRADA
TRANSVERSAL / DIREITA / LONGA
DIN 69 880 - B5

DIN 69 880 / RIGHT-HAND LONG
FORM - B5

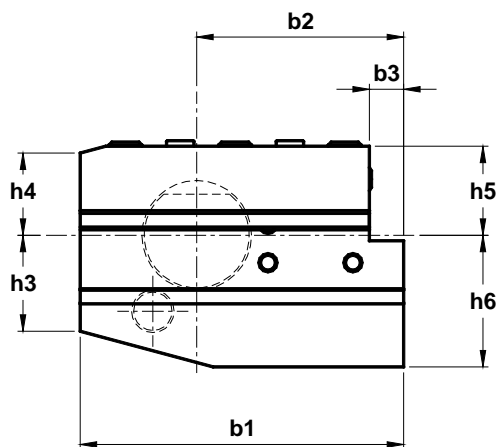
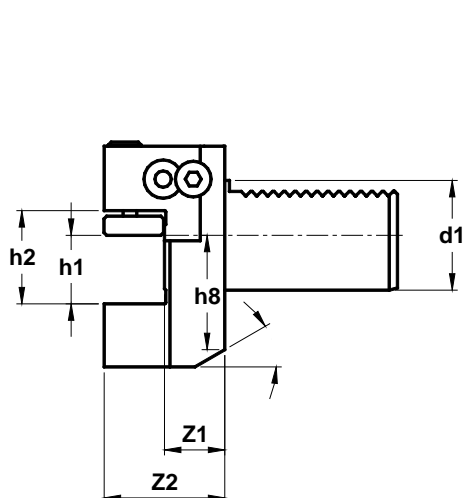

DIMENSÕES DA ADAPTAÇÃO ADAPTATION DIMENSIONS														CÓDIGO Code	
d1	b1	b2	b3	h1	h2	h3	h4	h5	h6	h8	Z1	Z2	α	Ref.	
20	75	50	7	16	22	19	19	25	30	23	16	30	30°	632 05 16	20054000039
30	100	65	10	20	29	26	22	28	38	30	22	40	25°	633 05 20	20054000041
40	118	75.5	12.5	25	34	35	30	32.5	48	-	22	44	-	634 05 25	20054000043
50	130	80	16	32	41	42	35	35	60	-	30	55	-	635 05 32	20054000044
60	145	82.5	16	32	41	46	42.5	42.5	62.5	-	30	60	-	636 05 32	20054000045
80	190	110	20	40	53	60	55	55	80	-	40	75	-	638 05 40	20054000046

Exemplo para pedido / Ordering example : 10 pçs - **20054000039**

**HASTE DIN 69 880, COM ADAPTAÇÃO
PARA HASTE QUADRADA
TRANSVERSAL / ESQUERDA / LONGA
DIN 69 880 - B6**

*DIN 69 880 / LEFT-HAND LONG
FORM - B6*

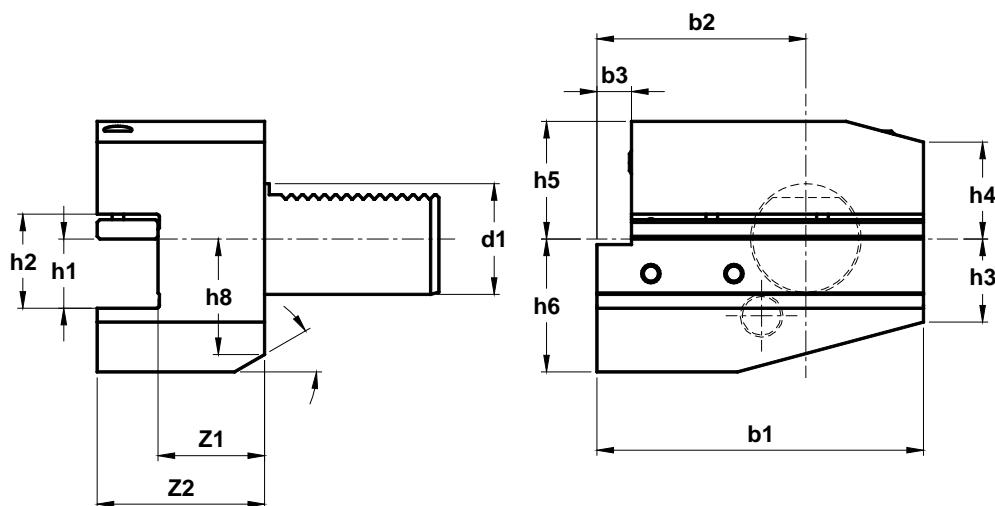

DIMENSÕES DA ADAPTAÇÃO
ADAPTATION DIMENSIONS

d1	b1	b2	b3	h1	h2	h3	h4	h5	h6	h8	Z1	Z2	α	Ref.	CÓDIGO Code
20	75	50	7	16	22	19	19	25	30	23	16	30	30°	632 06 16	20054000047
30	100	65	10	20	29	26	22	28	38	30	22	40	25°	633 06 20	20054000049
40	118	75.5	12.5	25	34	35	30	32.5	48	-	22	44	-	634 06 25	20054000051
50	130	80	16	32	41	42	35	35	60	-	30	55	-	635 06 32	20054000052
60	145	82.5	16	32	41	46	42.5	42.5	62.5	-	30	60	-	636 06 32	20054000053
80	190	110	20	40	53	60	55	55	80	-	40	75	-	638 06 40	20054000054

Exemplo para pedido / Ordering example : 10 pçs - **20054000047**

**HASTE DIN 69 880, COM ADAPTAÇÃO
PARA HASTE QUADRADA
TRANSVERSAL / POSIÇÃO INVERSA / DIREITA / LONGA
DIN 69 880 - B7**

*DIN 69 880 / RIGHT-HAND LONG INVERTED
FORM - B7*

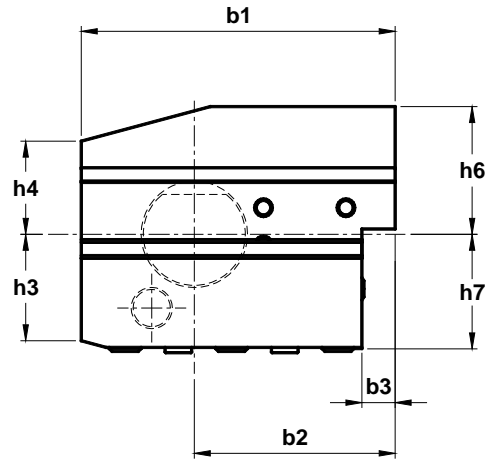
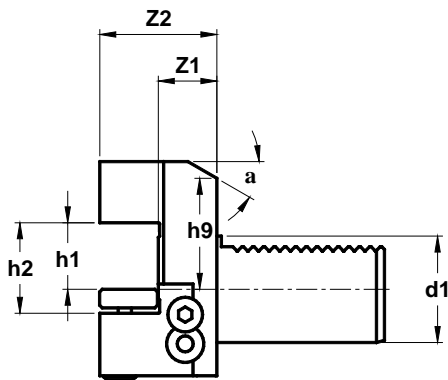

DIMENSÕES DA ADAPTAÇÃO
ADAPTATION DIMENSIONS

d1	b1	b2	b3	h1	h2	h3	h4	h6	h7	h9	Z1	Z2	α	Ref.	CÓDIGO Code
20	75	50	7	16	22	19	19	30	25	23	16	30	30°	632 07 16	20054000055
30	100	65	10	20	29	26	22	38	35	28	22	40	25°	633 07 20	20054000057
40	118	75.5	12.5	25	34	35	30	48	42.5	-	22	44	-	634 07 25	20054000059
50	130	80	16	32	41	42	35	60	50	-	30	55	-	635 07 32	20054000060
60	145	82.5	16	32	41	46	42.5	62.5	62.5	-	30	60	-	636 07 32	20054000061
80	190	110	20	40	53	60	55	80	80	-	40	75	-	638 07 40	20054000062

Exemplo para pedido / Ordering example : 10 pçs - **20054000055**

VDI SUPORTES / VDI Turning Toolholders

HASTE DIN 69 880, COM ADAPTAÇÃO
PARA HASTE QUADRADA
TRANSVERSAL / POSIÇÃO INVERSA / ESQUERDA / LONGA
DIN 69 880 - B8

DIN 69 880 / LEFT-HAND LONG INVERTED
FORM - B8

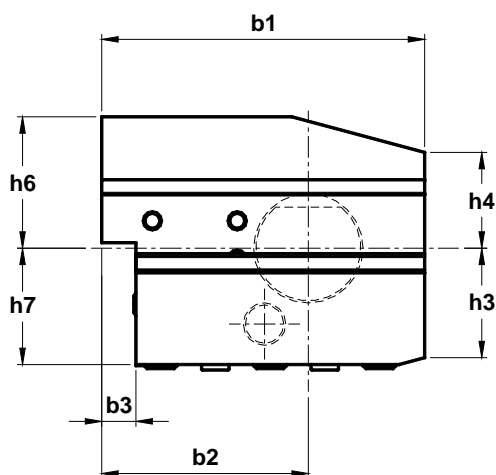
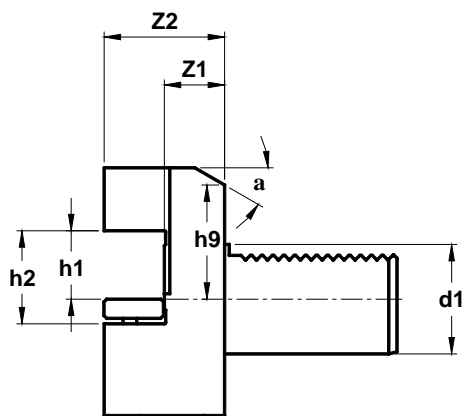

DIMENSÕES DA ADAPTAÇÃO
ADAPTATION DIMENSIONS

d1	b1	b2	b3	h1	h2	h3	h4	h6	h7	h9	Z1	Z2	α	Ref.	CÓDIGO Code
20	75	50	7	16	22	19	19	30	25	23	16	30	30°	632 08 16	20054000063
30	100	65	10	20	29	26	22	38	35	28	22	40	25°	633 08 20	20054000065
40	118	75.5	12.5	25	34	35	30	48	42.5	-	22	44	-	634 08 25	20054000067
50	130	80	16	32	41	42	35	60	50	-	30	55	-	635 08 32	20054000068
60	145	82.5	16	32	41	46	42.5	62.5	62.5	-	30	60	-	636 08 32	20054000069
80	190	110	20	40	53	60	55	80	80	-	40	75	-	638 08 40	20054000070

Exemplo para pedido / Ordering example : 10 pçs - 20054000063

**HASTE DIN 69 880, COM ADAPTAÇÃO
PARA HASTE QUADRADA
LONGITUDINAL / DIREITA
DIN 69 880 - C1**

*DIN 69 880 / SQUARE RIGHT-HAND
FORM - C1*

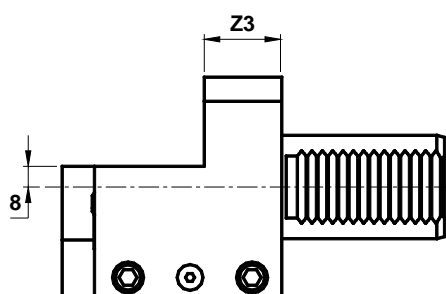
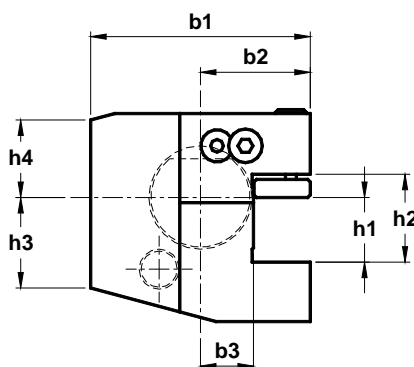
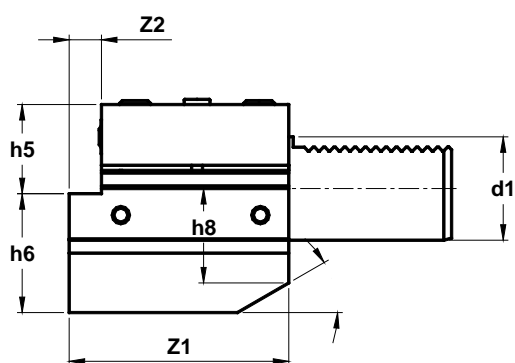

DIMENSÕES DA ADAPTAÇÃO ADAPTATION DIMENSIONS															CÓDIGO Code	
d1	b1	b2	b3	h1	h2	h3	h4	h5	h6	h8	Z1	Z2	Z3	α	Ref.	
20	52	27	13	16	22	19	19	25	30	23	55	7	30	30°	642 01 16	20054000071
30	70	35	17	20	29	26	22	28	38	30	70	10	30	25°	643 01 20	20054000073
40	85	42.5	20.5	25	34	35	30	32.5	48	-	85	12.5	30	-	644 01 25	20054000074
50	100	50	25.5	32	41	42	35	35	60	-	100	16	40	-	645 01 32	20054000075
60	125	62.5	32.5	32	41	46	42.5	42.5	62.5	-	125	16	40	-	646 01 32	20054000076
80	160	80	41	40	53	60	55	55	80	-	160	20	40	-	648 01 40	20054000077

Exemplo para pedido / Ordering example : 10 pcs - **20054000071**

**HASTE DIN 69 880, COM ADAPTAÇÃO
PARA HASTE QUADRADA
LONGITUDINAL / ESQUERDA
DIN 69 880 - C2**

*DIN 69 880 / SQUARE LEFT-HAND
FORM - C2*

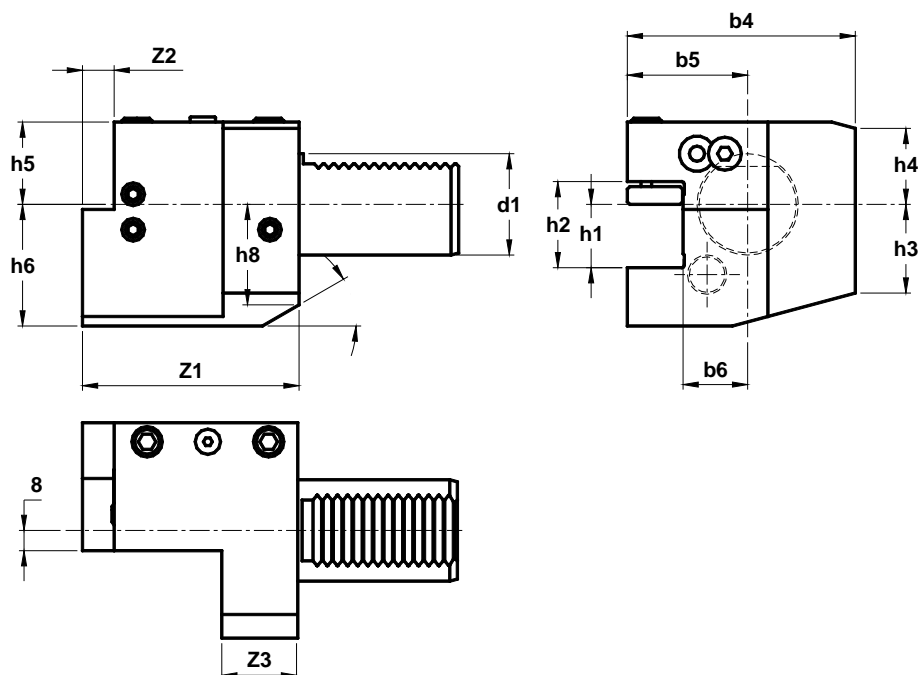

DIMENSÕES DA ADAPTAÇÃO
ADAPTATION DIMENSIONS

d1	b4	b5	b6	h1	h2	h3	h4	h5	h6	h8	Z1	Z2	Z3	α	Ref.	CÓDIGO Code
20	65	40	26	16	22	19	19	25	30	23	55	7	30	30°	642 02 16	20054000078
30	76	41	23	20	29	26	22	28	38	30	70	10	30	25°	643 02 20	20054000080
40	90	47.5	25.5	25	34	35	30	32.5	48	-	85	12.5	30	-	644 02 25	20054000081
50	105	55	30.5	32	41	42	35	35	60	-	100	16	40	-	645 02 32	20054000082
60	125	62.5	32.5	32	41	46	42.5	42.5	62.5	-	125	16	40	-	646 02 32	20054000083
80	160	78	41	40	53	60	55	55	80	-	160	20	40	-	648 02 40	20054000084

Exemplo para pedido / Ordering example : 10 pçs - **20054000078**

**HASTE DIN 69 880, COM ADAPTAÇÃO
PARA HASTE QUADRADA
LONGITUDINAL / POSIÇÃO INVERSA / DIREITA
DIN 69 880 - C3**

*DIN 69 880 / SQUARE RIGHT-HAND INVERTED
FORM - C3*

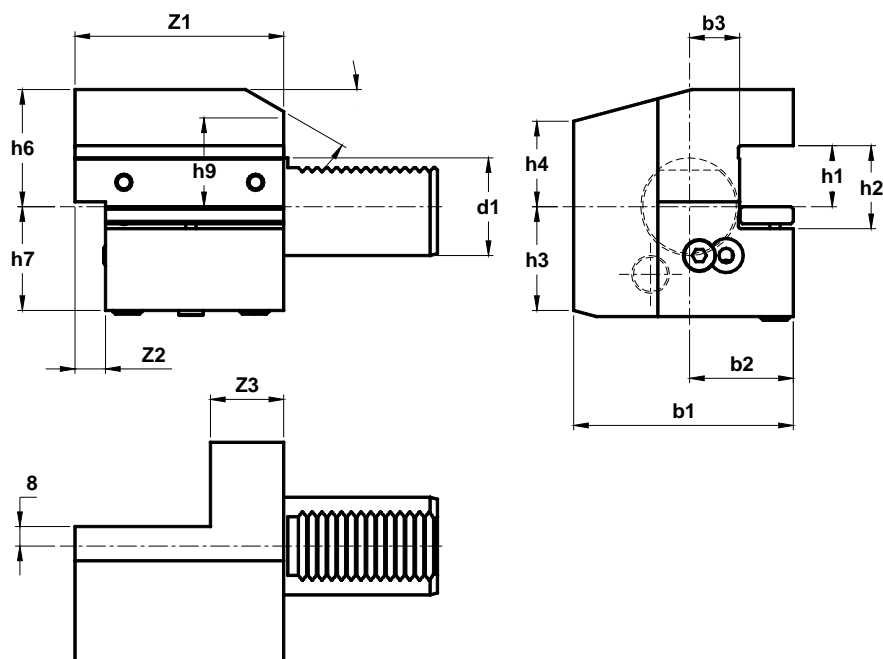

DIMENSÕES DA ADAPTAÇÃO
ADAPTATION DIMENSIONS

d1	b1	b2	b3	h1	h2	h3	h4	h6	h7	h9	Z1	Z2	Z3	α	Ref.	CÓDIGO Code
20	52	27	13	16	22	19	19	30	25	23	55	7	30	30°	642 03 16	20054000085
30	70	35	17	20	29	26	22	38	35	28	70	10	30	25°	643 03 20	20054000087
40	85	42.5	20.5	25	34	35	30	48	42.5	-	85	12.5	30	-	644 03 25	20054000088
50	100	50	25.5	32	41	42	35	60	50	-	100	16	40	-	645 03 32	20054000089
60	125	62.5	32.5	32	41	46	42.5	62.5	62.5	-	125	16	40	-	646 03 32	20054000090
80	160	80	41	40	53	60	55	80	80	-	160	20	40	-	648 03 40	20054000091

Exemplo para pedido / Ordering example : 10 pçs - **20054000085**

VDI SUPORTES / VDI Turning Toolholders

HASTE DIN 69 880, COM ADAPTAÇÃO
PARA HASTE QUADRADA
LONGITUDINAL / POSIÇÃO INVERSA / ESQUERDA
DIN 69 880 - C4

DIN 69 880 / SQUARE LEFT-HAND INVERTED
FORM - C4

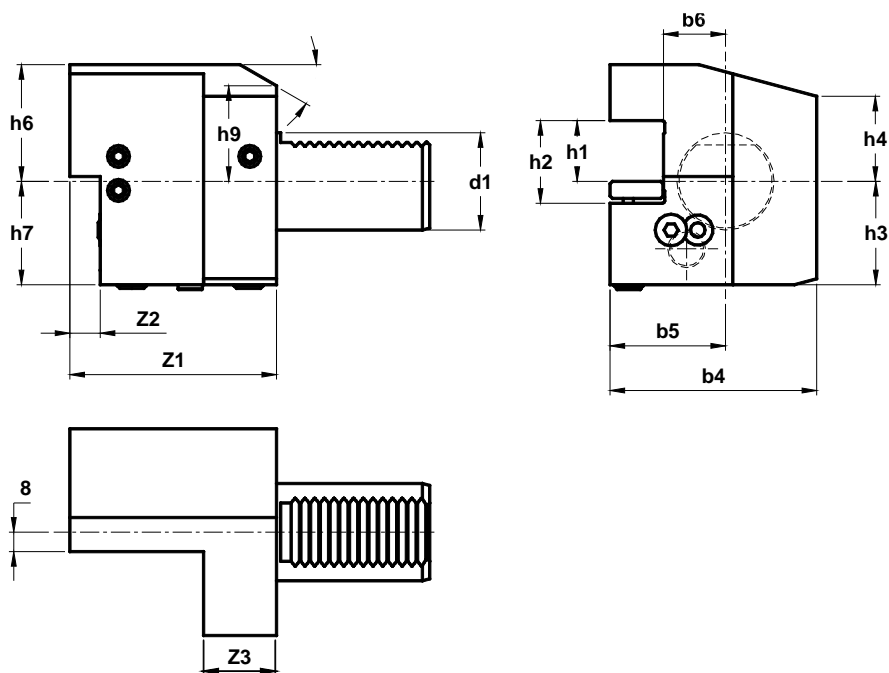

DIMENSÕES DA ADAPTAÇÃO
ADAPTATION DIMENSIONS

d1	b4	b5	b6	h1	h2	h3	h4	h6	h7	h8	Z1	Z2	Z3	α	Ref.	CÓDIGO Code
20	65	40	26	16	22	19	19	30	25	23	55	7	30	30°	642 04 16	20054000092
30	76	41	23	20	29	26	22	38	35	30	70	10	30	25°	643 04 20	20054000094
40	90	47.5	25.5	25	34	35	30	48	42.5	-	85	12.5	30	-	644 04 25	20054000095
50	105	55	30.5	32	41	42	35	60	50	-	100	16	40	-	645 04 32	20054000096
60	125	62.5	32.5	32	41	46	42.5	62.5	62.5	-	125	16	40	-	646 04 32	20054000097
80	160	78	41	40	53	60	55	80	80	-	160	20	40	-	648 04 40	20054000098

Exemplo para pedido / Ordering example : 10 pçs - **20054000092**

**HASTE DIN 69 880, COM ADAPTAÇÃO
PARA HASTE QUADRADA
MÚLTIPLO / TRANSVERSAL / LONGITUDINAL
DIN 69 880 - D1**

**DIN 69 880 / MULTI PURPOSE
SQUARE TOOLHOLDER
FORM - D1**

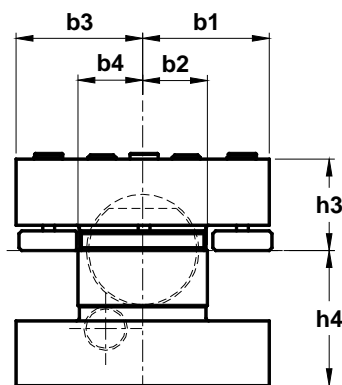
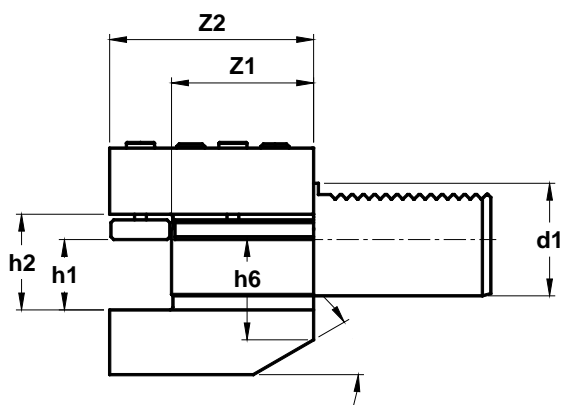

**DIMENSÕES DA ADAPTAÇÃO
ADAPTATION DIMENSIONS**

d1	b1	b2	b3	b4	h1	h2	h3	h4	h6	Z1	Z2	α	Ref.	CÓDIGO Code
30	35	17	41	23	20	29	28	38	30	42	60	25°	653 01 20	20054000099
40	42.5	20.5	47.5	25.5	25	34	32.5	48	-	50	72	-	654 01 25	20054000100
50	50	25.5	55	30.5	32	41	35	60	-	60	85	-	655 01 32	20054000101
60	57.5	32.5	57.5	32.5	32	41	42.5	62.5	-	85	110	-	656 01 32	20054000102
80	76	41	76	41	40	53	55	80	-	105	140	-	658 01 40	20054000103

Exemplo para pedido / Ordering example : 10 pçs - **20054000099**

VDI SUPORTES / VDI Turning Toolholders

**HASTE DIN 69 880, COM ADAPTAÇÃO
PARA HASTE QUADRADA
MÚLTIPLO / TRANSVERSAL / LONGITUDINAL
POSIÇÃO INVERSA
DIN 69 880 - D2**

**DIN 69 880 / MULTI PURPOSE
SQUARE TOOLHOLDER OVERHEAD
FORM - D2**

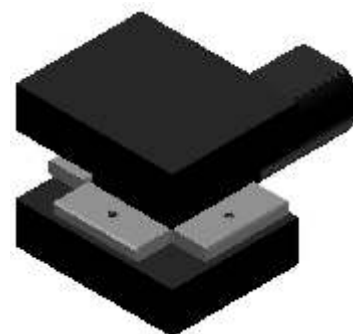
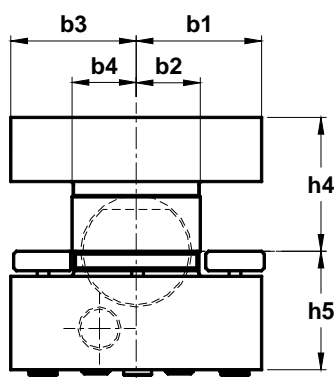
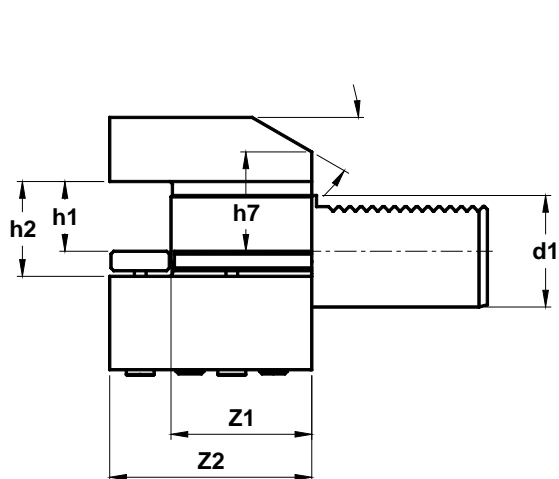

DIMENSÕES DA ADAPTAÇÃO ADAPTATION DIMENSIONS														CÓDIGO Code
d1	b1	b2	b3	b4	h1	h2	h4	h5	h7	Z1	Z2	α	Ref.	
30	35	17	41	23	20	29	38	35	28	42	60	25°	653 02 20	20054000104
40	42.5	20.5	47.5	25.5	25	34	48	42.5	-	50	72	-	654 02 25	20054000105
50	50	25.5	55	30.5	32	41	60	50	-	60	85	-	655 02 32	20054000106
60	57.5	32.5	57.5	32.5	32	41	62.5	62.5	-	85	110	-	656 02 32	20054000107
80	76	41	76	41	40	53	80	80	-	105	140	-	658 02 40	20054000108

Exemplo para pedido / Ordering example : 10 pçs - **20054000104**

**HASTE DIN 69 880, COM ADAPTAÇÃO
PARA HASTE CILÍNDRICA DE BROCA
FORMA - E1**

**DIN 69 880 / WITH SHAFT DRILL ADAPTATION
FORM - E1**

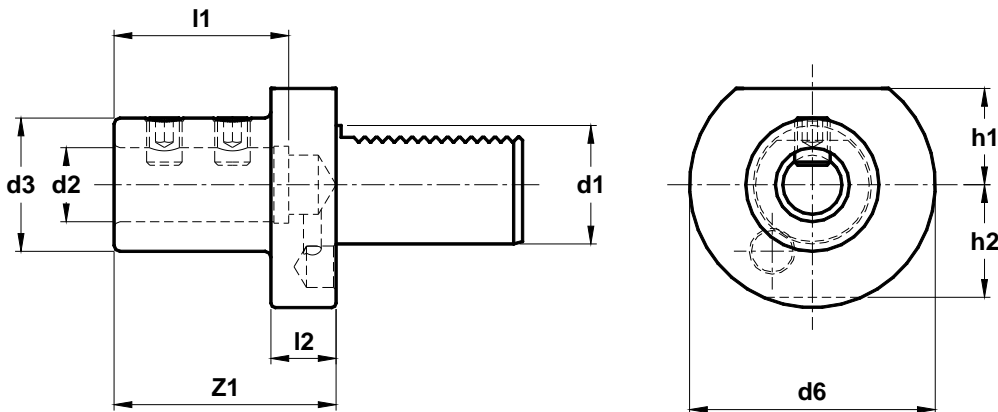

DIMENSÕES DA ADAPTAÇÃO ADAPTATION DIMENSIONS									Ref.	CÓDIGO Code
d1	d2	d3	d6	h1	h2	l1	l2	Z1		
20	16	40	50	-	23	41	18	50	662 01 16	20054000265
	20	40	50	-	23	54	18	67	662 01 20	20054000109
	25	45	50	-	23	59	18	71	662 01 25	20054000110
30	20	40	68	28	30	54	22	67	663 01 20	20054000111
	25	45	68	28	30	59	22	71	663 01 25	20054000112
	32	52	68	28	30	63	22	75	663 01 32	20054000113
40	20	40	83	32.5	-	54	22	67	664 01 20	20054000114
	25	45	83	32.5	-	59	22	75	664 01 25	20054000115
	32	52	83	32.5	-	63	22	75	664 01 32	20054000116
	40	60	83	32.5	-	73	22	90	664 01 40	20054000117
50	20	40	98	35	-	54	30	67	665 01 20	20054000118
	25	45	98	35	-	59	30	80	665 01 25	20054000119
	32	52	98	35	-	63	30	80	665 01 32	20054000120
	40	60	98	35	-	73	30	90	665 01 40	20054000121
	50	70	98	35	-	83	30	100	665 01 50	20054000122
60	20	40	123	42.5	-	54	30	80	666 01 20	20054000123
	25	45	123	42.5	-	59	30	80	666 01 25	20054000124
	32	52	123	42.5	-	63	30	80	666 01 32	20054000125
	40	60	123	42.5	-	73	30	90	666 01 40	20054000126
	50	70	123	42.5	-	83	30	100	666 01 50	20054000127
80	20	40	158	55	-	54	30	80	668 01 20	20054000128
	25	45	158	55	-	59	30	80	668 01 25	20054000129
	32	52	158	55	-	63	30	80	668 01 32	20054000130
	40	60	158	55	-	73	30	90	668 01 40	20054000131
	50	70	158	55	-	83	30	100	668 01 50	20054000132

Exemplo para pedido / Ordering example : 10 pcs - 20054000109

Bucha redutora pág.: 23
Reducing sleeve page: 23



**HASTE DIN 69 880 COM ADAPTAÇÃO PARA
HASTE CILÍNDRICA DE FERRAMENTA
COM FACETADO
DIN 69 880 - E2**

**DIN 69 880 / CILINDRICAL SHAFT ADAPTATION
FORM - E2**

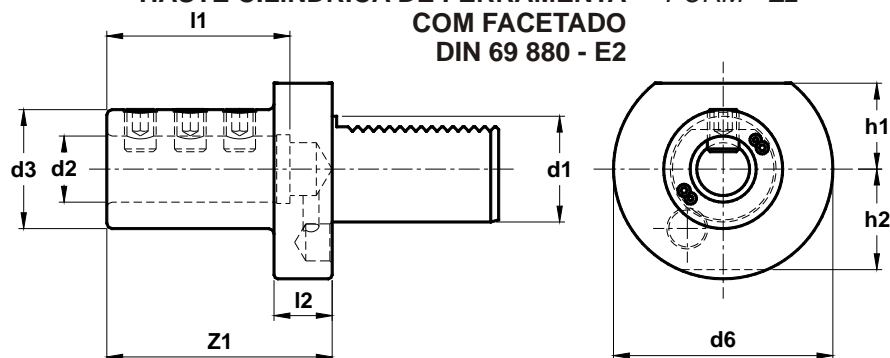

**DIMENSÕES DA ADAPTAÇÃO
ADAPTATION DIMENSIONS**

d1	d2	d3	d6	h1	h2	l1	l2	Z1	Ref.	CÓDIGO Code
20	8	40	50	-	23	41	18	50	662 02 08	20054000133
	10			-					662 02 10	20054000134
	12			-					662 02 12	20054000135
	16	40		-					662 02 16	20054000136
	20	50		-		41		50	662 02 20	20054000137
	25	50	50	-	23	51	18	60	662 02 25	20054000138
30	8	55	68	28	30		22		663 02 08	20054000139
	10								663 02 10	20054000140
	12								663 02 12	20054000141
	16								663 02 16	20054000142
	20								663 02 20	20054000143
	25	55				51		60	663 02 25	20054000144
	32	68	68	28	30	61		75	663 02 32	20054000145
40	12	55	83	32	-				664 02 12	20054000146
	16				-				664 02 16	20054000147
	20				-				664 02 20	20054000148
	25	55			-				664 02 25	20054000149
	32	83			-	61		75	664 02 32	20054000150
	40	83	83	32	-	76	22	90	664 02 40	20054000151
50	16	68	98	35	-		30		665 02 16	20054000152
	20				-				665 02 20	20054000153
	25				-				665 02 25	20054000154
	32	68			-				665 02 32	20054000155
	40	98			-	76		90	665 02 40	20054000156
	50	98	98	35	-	86		100	665 02 50	20054000157
60	16	68	123	42.5	-	76		90	666 02 16	20054000158
	20				-				666 02 20	20054000159
	25				-				666 02 25	20054000160
	32	68			-				666 02 32	20054000161
	40	98			-	76		90	666 02 40	20054000162
	50	98	123	42.5	-	86		100	666 02 50	20054000163
80	20	68	158	55	-				668 02 20	20054000164
	25				-				668 02 25	20054000165
	32	68			-				668 02 32	20054000166
	40	98			-				668 02 40	20054000167
	50	98	158	55	-	86	30	100	668 02 50	20054000168

Exemplo para pedido / Ordering example : 10 pçs - **20054000133**



BUCHA REDUTORA TIPO "C" *Tool Holder Bushing Type "C"*

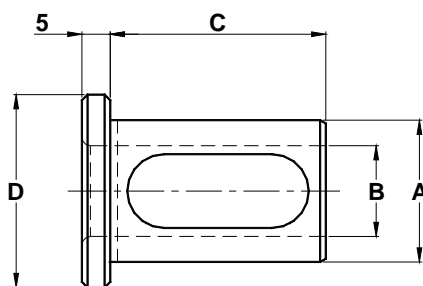

FORMA - E1



Página: 21
page: 21

A	B	C	D	CÓDIGO Code
25	16	38	31	26146000018
	20	51	31	26146000019
32	20	51	38	26146000020
	25	56	38	26146000021
40	20	51	46	26146000022
	25	56	46	26146000023
	32	60	46	26146000024
50	20	51	56	26146000025
	25	56	56	26146000026
	32	60	56	26146000027
	40	70	56	26146000028

Exemplo para pedido : 10 pçs - **216146000018**
Ordering example

FORMA - E2



Página: 22
page: 22

A	B	C	D	CÓDIGO Code
25	12	38	31	26146000029
		48	31	26146000030
		58	31	26146000031
25	16	38	31	26146000032
		48	31	26146000033
		58	31	26146000034
		73	31	26146000035
25	20	38	31	26146000036
		48	31	26146000037
		58	31	26146000038
		73	31	26146000039
		83	31	26146000040
32	16	48	38	26146000041
		58	38	26146000042
		73	38	26146000043
32	20	48	38	26146000044
		58	38	26146000045
		73	38	26146000046
		83	38	26146000047
32	25	48	38	26146000048
		58	38	26146000049
		73	38	26146000050
40	20	83	38	26146000051
		58	46	26146000052
		73	46	26146000053
		83	46	26146000054
		58	46	26146000055
40	25	73	46	26146000056
		83	46	26146000057
		58	46	26146000058
40	32	73	46	26146000059
		83	46	26146000060
50	25	73	56	26146000061
		83	56	26146000062
50	32	73	56	26146000063
		83	56	26146000064
50	40	73	56	26146000065
		83	56	26146000066

Exemplo para pedido : 10 pçs - **216146000029**
Ordering example

VDI SUPORTES / VDI Collet Chucks

**HASTE DIN 69 880, COM ADAPTAÇÃO PARA
HASTE CILÍNDRICA DE FERRAMENTA
COM OU SEM FACETADO**

*DIN 69 880 / CILINDRICAL SHAFT ADAPTATION
WITH OR WITHOUT MILL*

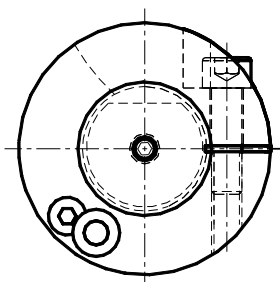
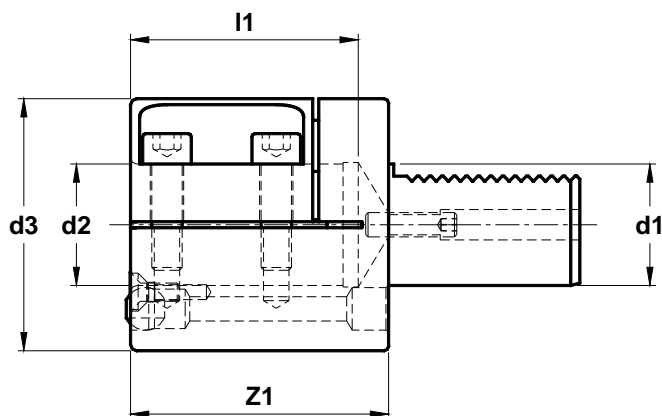

DIMENSÕES DA ADAPTAÇÃO ADAPTATION DIMENSIONS

d1	d2	d3	l1	Z1	Ref.	CÓDIGO Code
30	32	68	65	75	663 15 32	20054000170
40	40	83	75	85	664 15 40	20054000171
40	40	85	112	125	664 16 40	20054000172

Exemplo para pedido / Ordering example : 10 pçs - **20054000170**

BUCHAS REDUTORAS REDUCING SLEEVE

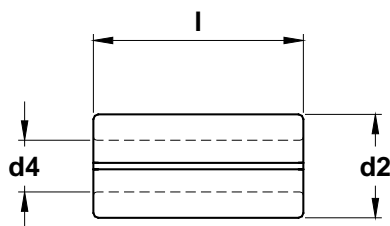

DIMENSÕES DA ADAPTAÇÃO ADAPTATION DIMENSIONS

d2	d4	L	Ref.	CÓDIGO Code
32	8	65	BRR 011-N	26146000001
	10		BRR 012-N	26146000002
	12		BRR 013-N	26146000003
	15		BRR 014-N	26146000004
	16		BRR 015-N	26146000005
	20		BRR 016-N	26146000006
32	25	65	BRR 017-N	26146000007
40	8	75	BRR 001-N	26146000009
	10		BRR 002-N	26146000010
	12		BRR 003-N	26146000011
	15		BRR 004-N	26146000012
	16		BRR 005-N	26146000013
	20		BRR 006-N	26146000014
	25		BRR 007-N	26146000015
	30		BRR 008-N	26146000016
	32		BRR 009-N	26146000017

Exemplo para pedido / Ordering example : 10 pçs - **26146000001**

**HASTE DIN 69 880 COM ADAPTAÇÃO
PORTA PINÇA DIN 6499-C
DIN 69 880 - E4**

**DIN 69 880 / DIN 6499 - C COLLET CHUCK
ADAPTATION
FORM - E4**

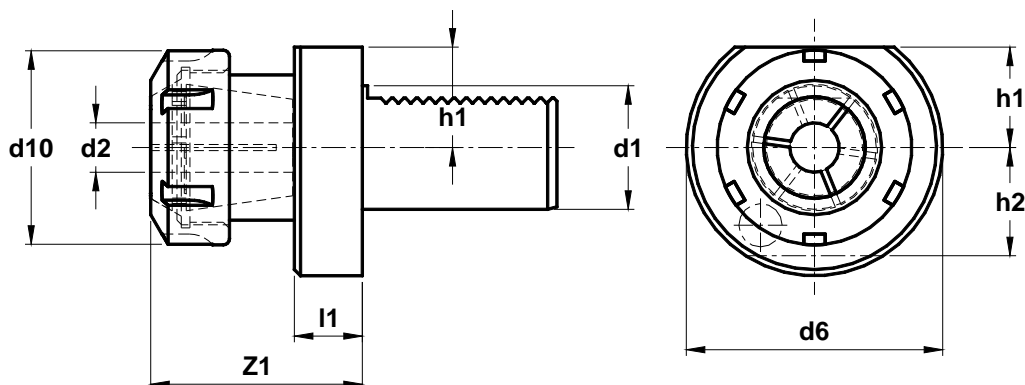

**DIMENSÕES DA ADAPTAÇÃO
ADAPTATION DIMENSIONS**

DIN 6499											
d1	Tamanho Size	Forma A Form A	Forma B Form B	d6	d10	h1	h2	l1	Z1	Ref.	CÓDIGO Code
20	25	1 - 16	2 - 16	50	42	-	23	18	50	662 04 25	20054000173
	32	2 - 20	3 - 20	50	50	-	23	18	62	662 04 32	20054000174
30	25	1 - 16	2 - 16	68	42	28	30	22	57	663 04 25	20054000175
	32	2 - 20	3 - 20	68	50	28	30	22	62	663 04 32	20054000284
	40	3 - 26	4 - 26	68	63	28	30	22	70	663 04 40	20054000176
40	32	2 - 20	3 - 20	83	50	32.5	-	22	62	664 04 32	20054000177
	40	3 - 26	4 - 26	83	63	32.5	-	22	75	664 04 40	20054000178
50	40	3 - 26	4 - 26	98	63	35	-	30	75	665 04 40	20054000179
60	40	3 - 26	4 - 26	123	63	42.5	-	30	75	666 04 40	20054000180
80	40	3 - 26	4 - 26	158	63	55	-	40	75	668 04 40	20054000181

Exemplo para pedido / Ordering example : 10 pçs - **20054000173**

Pinça tipo ER não fornecida,
deve ser solicitada
separadamente



Catálogo
ADAPTADOR MODULAR - pág. 22

VDI SUPORTES / VDI Turning Toolholders

**HASTE DIN 69 880, COM ADAPTAÇÃO
CONE MORSE INTERNO DIN 228 - MK - DK
DIN 69 880 - F**

*DIN 69 880 / TAPER SHANK WITH DIN 228 - MK - DK
(MORSE TAPER SOCKET)
ADAPTATION
FORM - F*

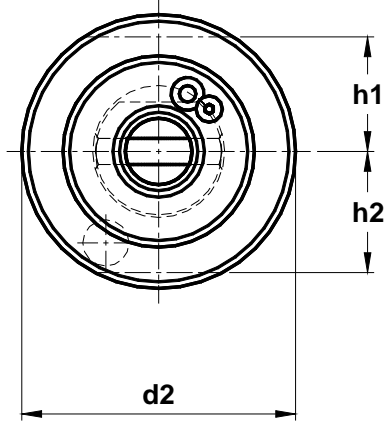
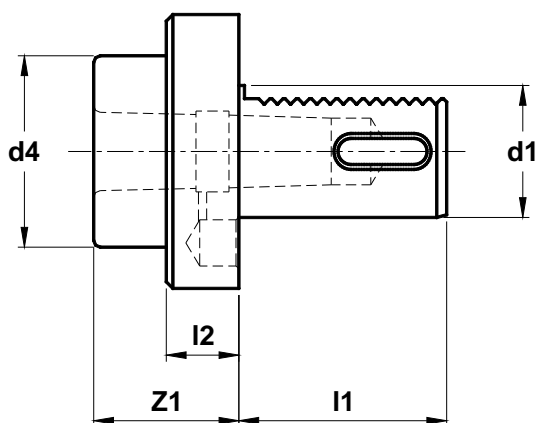

DIMENSÕES DA ADAPTAÇÃO ADAPTATION DIMENSIONS

d1	Cone Morse Morse Taper	d2	d4	h1	h2	l1	l2	Z1	Ref.	CÓDIGO Code
20	CM 1	50	-	-	23	40	-	23	672 01 01	20054000182
30	CM 1	68	-	28	30	55	-	27	673 01 01	20054000183
	CM 2	68	-	28	30	55	-	27	673 01 02	20054000184
40	CM 2	83	55	32.5	-	63	22	36	674 01 02	20054000185
	CM 3	83	58	32.5	-	63	22	36	674 01 03	20054000186
	CM 4	83	68	32.5	-	63	30	80	674 01 04	20054000187
50	CM 2	98	55	35	-	78	30	36	675 01 02	20054000188
	CM 3	98	58	35	-	78	30	36	675 01 03	20054000189
	CM 4	98	68	35	-	78	30	50	675 01 04	20054000190
60	CM 3	123	58	42.5	-	94	30	36	676 01 03	20054000191
	CM 4	123	68	42.5	-	94	30	50	676 01 04	20054000192
	CM 5	123	98	42.5	-	94	30	63	676 01 05	20054000193
80	CM 4	158	68	55	-	104	40	50	678 01 04	20054000194
	CM 5	158	98	55	-	104	40	50	678 01 05	20054000195

Exemplo para pedido / Ordering example : 10 pçs - **20054000182**

**HASTE DIN 69 880 COM ADAPTAÇÃO
PORTA-MACHO TIPO "S"
COM COMPENSAÇÃO**

**DIN 69 880 / WITH TAP HOLDER ADAPTATION
TYPE "S" WITH COMPENSATION**

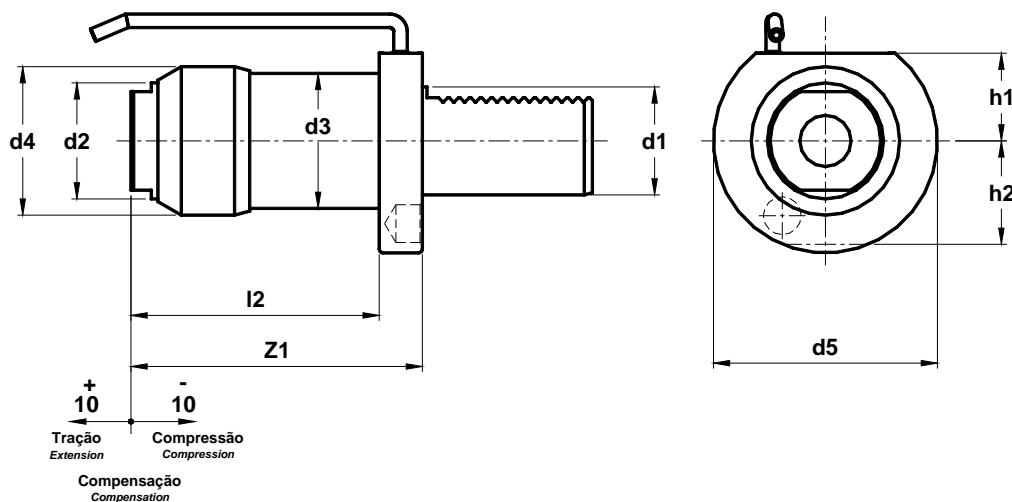

**DIMENSÕES DA ADAPTAÇÃO
ADAPTATION DIMENSIONS**

d1	Machos Tapers	Tamanho Size	d2	d3	d4	d5	h1	h2	l2	Z1	Ref.	CÓDIGO Code
30	M3-M10	0	26	50	-	68	28	30	112	127	613 35 18	20054000196
	M8-M20	1	43	50	55	68	28	30	115	130	613 35 16	20054000197
40	M3-M10	0	26	50	-	83	32.5	-	112	127	614 35 18	20054000198
	M8-M20	1	43	50	55	83	32.5	-	115	130	614 35 16	20054000199
	M20-M42	2	73	73	80	83	-	-	160	175	614 35 17	20054000200

Exemplo para pedido / Ordering example : 10 pçs - **20054000196**

Pinças Catálogo : **ACESSÓRIOS**
Collets Catalog : **ACCESSORIES**



**HASTE DIN 69 880 COM ADAPTAÇÃO
PORTA-MACHO TROCA RÁPIDA
COM COMPENSAÇÃO**

**DIN 69 880 / WITH TAP HOLDER ADAPTATION
QUICK CHANGE WITH COMPENSATION**

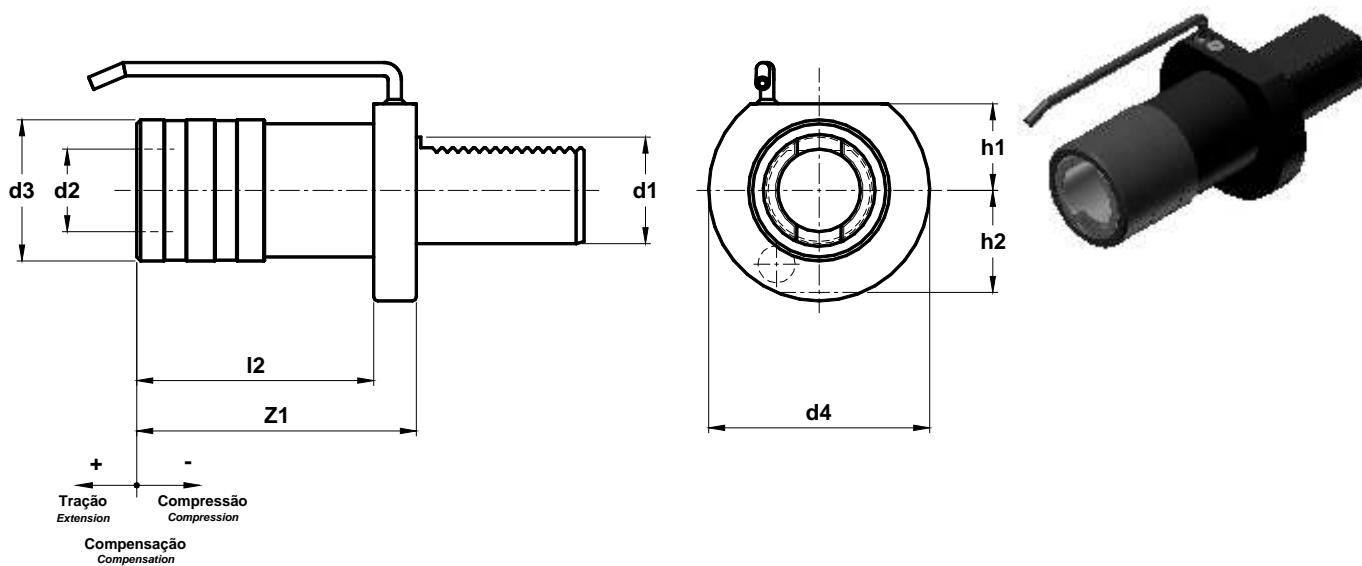

**DIMENSÕES DA ADAPTAÇÃO
ADAPTATION DIMENSIONS**

d1	Machos Tapers	Tamanho Size	Compensação Compensation		d2	d3	d4	h1	h2	l2	Z1	Ref.	CÓDIGO Code
			-	+									
30	M3-M12	1	7.5	7.5	19	36	68	28	30	45	60	613 35 21	20054000201
	M8-M20	2	12.5	12.5	31	53	68	28	30	65	80	613 35 22	20054000202
40	M3-M12	1	7.5	7.5	19	36	83	32.5	-	45	60	614 35 21	20054000203
	M8-M20	2	12.5	12.5	31	53	83	32.5	-	65	80	614 35 22	20054000204
	M14-M33	3	20	20	48	78	83	-	-	120	135	614 35 23	20054000205

Exemplo para pedido / Ordering example : 10 pçs - 20054000201

Pinças Catálogo : ACESSÓRIOS
Collets Catalog : ACCESSORIES



HASTE DIN 69 880 COM ADAPTAÇÃO
CONE DIN 238 - B

DIN 69 880 - WITH DIN 238 - B
TAPER ADAPTATION

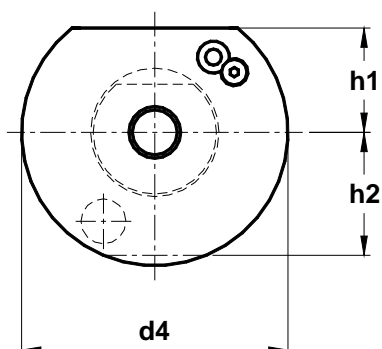
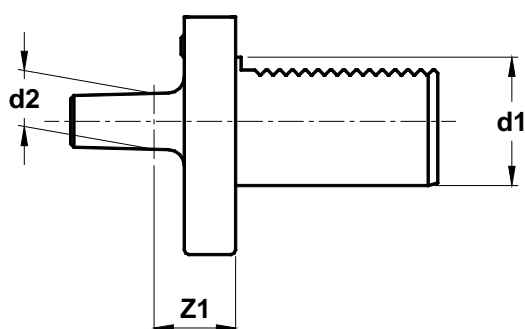

DIMENSÕES DA ADAPTAÇÃO ADAPTATION DIMENSIONS						Capacidade Capacity		Ref.	CÓDIGO Code
d1	d2	d3	h1	h2	Z1	de / from	até / until		
30	B10	68	28	30	25	0.5	4	613 00 10	20054000206
	B12	68	28	30	25	0.8 0.8	6.3 8	613 00 12	20054000207
	B16	68	28	30	26	1 1	10 13	613 00 16	20054000208
40	B10	83	32.5	-	29	0.5	4	614 00 10	20054000209
	B12	83	32.5	-	29	0.8 0.8	6.3 8	614 00 12	20054000210
	B16	83	32.5	-	30	1 1	10 13	614 00 16	20054000211
	B18	83	32.5	-	30	1	16	614 00 18	20054000212
	B22	83	32.5	-	30	5	20	614 00 22	20054000213
	B24	83	32.5	-	30	5	26	614 00 24	20054000214

Exemplo para pedido / Ordering example : 10 pçs - 20054000206

VDI SUPORTES / VDI Turning Toolholders

HASTE DIN 69 880 COM ADAPTAÇÃO CONE ISO/R 239 (JACOB'S) *DIN 69 880 - WITH ISO/R 239 TAPER (JACOB'S) ADAPTATION*

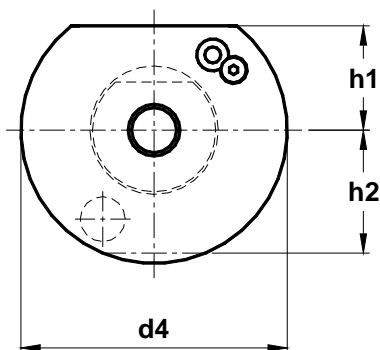
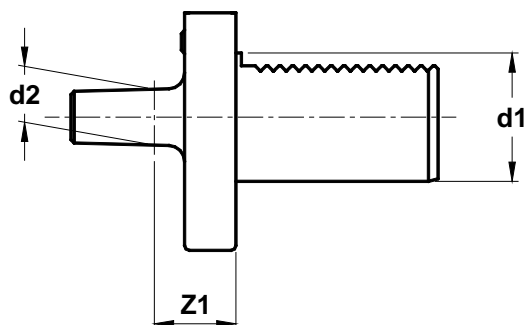

DIMENSÕES DA ADAPTAÇÃO ADAPTATION DIMENSIONS

d1	d2	d3	h1	h2	Z1	Capacidade Capacity		Ref.	CÓDIGO CODE
						de / from	até / until		
30	J1	68	28	30	25	0.5 0.5	6.5 8	613 22 01	20054000215
	J2	68	28	30	25	1	10	613 22 02	20054000216
	J33	68	28	30	26	1	13	613 22 33	20054000217
	J6	68	28	30	26	1 1	13 16	613 22 06	20054000218
	J3	68	28	30	26	1 5	16 20	613 22 03	20054000219
40	J1	83	32.5	-	29	0.5 0.5	6.5 8	614 22 01	20054000220
	J2	83	32.5	-	29	1	10	614 22 02	20054000221
	J33	83	32.5	-	30	1	13	614 22 33	20054000222
	J6	83	32.5	-	30	1 1	13 16	614 22 06	20054000223
	J3	83	32.5	-	30	1 5	16 20	614 22 03	20054000224

Exemplo para pedido / Ordering example : 10 pçs - 20054000215

ANEL DE ENCOSTO / DIN 69 880 - Z1

Clamping Ring / DIN 69 880 - Z1

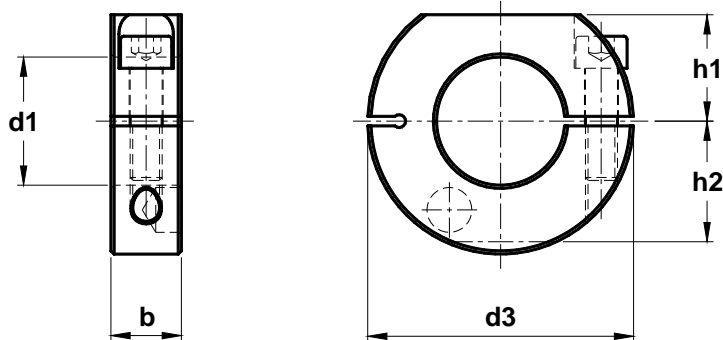

DIMENSÕES DA ADAPTAÇÃO ADAPTATION DIMENSIONS							CÓDIGO Code
d1	b	d3	h1	h2	Ref.		
20	16	50	23	23	682 01 16	2614000001	
30	22	68	28	30	683 01 22	2614000002	
40	22	83	32.5	-	684 01 22	2614000003	
50	30	98	35	-	685 01 30	2614000004	
60	30	123	42.5	-	686 01 30	2614000005	
80	40	158	55	-	688 01 40	2614000006	

Exemplo para pedido / Ordering example : 10 pçs - **2614000001**

TAMPÃO / DIN 69 880 - Z2

Plug / DIN 69 880 - Z2

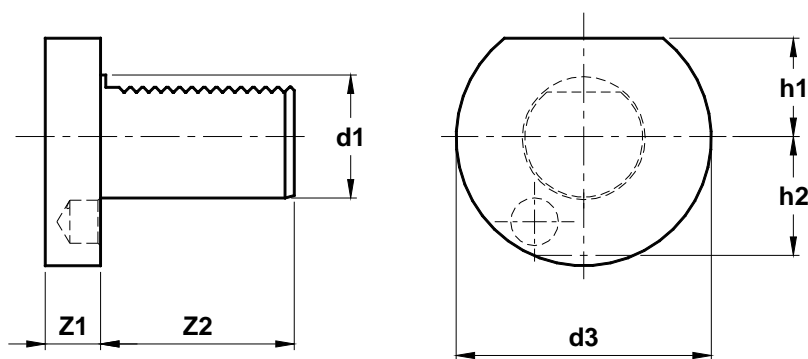

DIMENSÕES DA ADAPTAÇÃO ADAPTATION DIMENSIONS							CÓDIGO Code
d1	d3	h1	h2	Z1	Z2	Ref.	
20	50	23	23	16	40	682 02 20	2005500007
30	68	28	30	16	55	683 02 30	2005500008
40	83	32.5	-	20	63	684 02 40	2005500009
50	98	35	-	20	78	685 02 50	2005500010
60	123	42.5	-	20	94	686 02 60	2005500011
80	158	55	-	20	124	688 02 80	2005500012

Exemplo para pedido / Ordering example : 10 pçs - **2005500007**

ISO 9001

BUREAU VERITAS
Certification



Projeto Gráfico - ROBERTO CAMPOS



EDIÇÃO - 02/07

YNOWA FERRAMENTAS LTDA
RUA CLÁUDIA SOARES, Nº 153 - BAIRRO PORTAL DO SOL
SÃO JOSÉ DOS PINHAIS - PARANÁ - CEP 83020-790

Fone: (41)3595-4545 - Fax: (41)3595-4546

CNPJ: 08.089.188/0001-06

INSC. EST.: 90.375.281-50

E-mail: ynowa@ynowa.com.br

Site: www.ynowa.com.br

EMS - 92585000103

Representante: _____

